

Equipment – Barrel Handling – Barrel Grabs



All products direct from the manufacturer

# THE WHOLE BARREL RANGE

2nd edition

Lifting

Tilting

Emptying

Filling

Mixing

Storing

Transporting





## planning, production and delivery

A long-standing company with 80 years of experience in the field of barrel and storage technology and the construction of lifting gear.

We have a solution to your task thanks to our years of practical experience and highest standards of quality.

All **MEILLER** products are certified according to regulation.

### Handling equipment

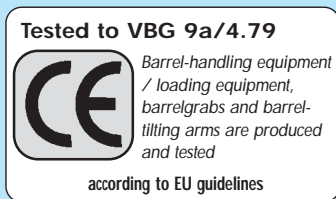

#### Machines 98/37/EG

**MEILLER** is a specialised company tested and approved according to § 19 I of the Water-Resources Law.

Our production complies fully with current regulations such as TRbFand StawaR.

For our products in the fields of toxic-substance storage / surface-protection elements, basement water-proofing, compartment containers, tank containers, spillage tanks in standard and special designs, storage containers, barrel-stacking pallets, safety-module containers

**-please ask for our catalogue-**

General  
Approval of Construction-  
Supervisory Authority, list A, part 1  
DIBt. Berlin

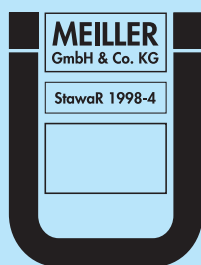

Since 1983 we have been producing bicycle and car shelters, bicycle stands, tables and benches successfully using purchased parts. (Please ask for our catalogue).

We carry out high-precision laser cutting operations on steel, stainless-steel and aluminium using our NC laser cutting unit with loading and unloading machinery. The material is for our own production as well as contract work. (Enquiries welcome).

### Contents:

| Page:   | Description   |
|---------|---|
| 04      | Barrel trolleys for steel and plastic barrels                 |
| 05      | Barrel tilter for 50, 100 and 200 litre barrels               |
| 06      | Barrel tilter for steel and plastic barrels                   |
| 07 – 08 | Barrel-handling equipment                                     |
| 09 – 11 | Barrel transport  |
| 12 – 14 | Barrel-grab / barrel harness                                  |
| 15      | Barrel-tilting grabs / beams                                  |
| 16      | Barrel-turners / adjustable beams / barrel-tilting beams      |
| 17 – 20 | Fork-lift add-on systems                                      |
| 21      | Barrel manipulator  |
| 22      | Special types for cranes and fork-lifts                       |
| 23 – 24 | Barrel mixing units / mixing stations / elevators and turners |
| 25      | High-lift truck for stacking shelves                          |
| 26      | High-lift trucks / lifting and tilting units                  |
| 27      | Barrel-storage systems to WHG                                 |
| 28      | Heavy-duty pallet drawers for storage-shelf systems           |
| 29      | Work platforms  |
| 30 – 31 | Long-material cassettes / chassis                             |
| 32      | Crane jibs as fork-lift add-on units                          |
| 33 – 35 | Workshop and assembly cranes, manual and electrically powered |
| 36 – 37 | Mobile industrial cranes                                      |

**Made in Germany**





Our 3 KW laser unit with a working range of 1500 x 3000 mm cuts steel sheet up to 20 mm, stainless steel up to 8 mm and aluminium up to 6 mm in thickness with maximum precision and absolutely free of burrs.



## Steel-sheet processing to customer specification



Following restructuring, our highly modern machine park is also available for contract work to your specification e.g.

- CNC edging presses for production of edged profiles up to 6100 mm in length and 6.0 mm in thickness
- Cuts of up to 4000 mm in length and 8 mm in thickness
- Sawing and cutting to length / mitre cutting on automatic CNC machinery
- Manual or automatic welding by 2 welding robots
- Stamping and punching on semi-automatic machinery to lengths of up to 6000 mm

**For more information, contact:**  
**Mr. Gies - Tel. +49(0)29 72 / 97 42-19**





Art. no. FK-120

## Barrel trolley for 120 l plastic barrels

| Art. no. | Description  |
|----------|--|
| FK-120   | Barrel trolley for transport or filling stand, with belt, pneumatic tyres Ø 260 mm, Dimensions 470 x 1350 mm, max. load 200 kg finish: paint colour RAL 5015 |

Art. no. 1026-1



## Barrel-transport trolley

for plastic and steel barrels with pneumatic tyres

- For placing on storage pallets up to max. 400 mm high
- Strap included
- Suitable for use as filling stand
- Finish: paint colour RAL 5015

| Art. no. | Description                  |
|----------|------------------------------|
| 1026-1   | Barrel-transport trolley     |
|          | <b>Accessories</b>           |
| VG       | Solid rubber wheels Ø 400 mm |



**Barrel trolley** without support wheel, Solid-rubber wheels Ø 250 mm, Dimensions: 660 x 1600 mm, Finish: paint colour RAL 5015 Max. load: 400 kg  
**Art. no. 1029-1**



**Barrel trolley** with support wheel, Solid-rubber wheels Ø 250 mm, Dimensions: 660 x 1600 mm, Finish: paint colour RAL 5015 Max. load: 400 kg  
**Art. no. 1029-2**



**Barrel trolley** without support wheel, Pneumatic tyres Ø 260 mm, Dimensions: 660 x 1600 mm, Finish: paint colour RAL 5015 Max. load: 400 kg  
**Art. no. 1029-3**



**Barrel trolley** with support wheel, Pneumatic tyres Ø 260 mm, Dimensions: 660 x 1600 mm, Finish: paint colour RAL 5015 Max. load: 400 kg  
**Art. no. 1029-4**



Art. no. 1027-1

## Barrel-transport trolley

with pneumatic tyres Ø 400 mm and 4 twin barrel rollers Ø 50 mm

- Transport of steel barrels
- For placing on storage pallets up to max. 400 mm in height
- Suitable as filling stand
- Finish: paint colour RAL 5015



Art. no. 1027-1 in filling position

| Art. no. | Description                    |
|----------|--------------------------------|
| 1027-1   | Barrel-transport trolley       |
|          | <b>Accessories</b>             |
| TR       | Metal support rollers (1 pair) |
| VG       | Solid rubber wheels Ø 400 mm   |

# Barrel tilter

**Our best idea since the invention of barrels**

The barrel tilters for 50, 60, 100 and 250 litre barrels, designed as handling devices are simple and effective aids for positioning barrels and pouring liquids which may be hazardous to water resources.

**Function:**

The barrels are lifting in the upright position, locked in position with the lever and then moved into transporting or pouring position by means of the roller runners.

Finish: paint colour RAL 5015



| Fig. | Type:   | Pouring height mm | Dimensions WxL mm | Wheel Ø mm fixed / swivel wheels | Weight kg | Art. no.      |
|------|---|-------------------|-------------------|----------------------------------|-----------|---------------|
| 1    | for 200 litre barrels with PVC barrel rollers                           | 550               | 500 x 830         | 125/100                          | 18,0      | <b>1032-1</b> |
| 2    | for 50-/60 litre barrels with PVC barrel rollers                        | 400               | 360 x 600         | 100/50                           | 13,0      | <b>1030-1</b> |
| 3    | for 50-/60 litre barrels with steel collector basin, capacity 61 litres | 550               | 460 x 850         | 100/-                            | 29,0      | <b>1030-W</b> |
| 4    | for 100 litre barrels with PVC barrel rollers                           | 450               | 380 x 700         | 100/50                           | 16,0      | <b>1031-1</b> |

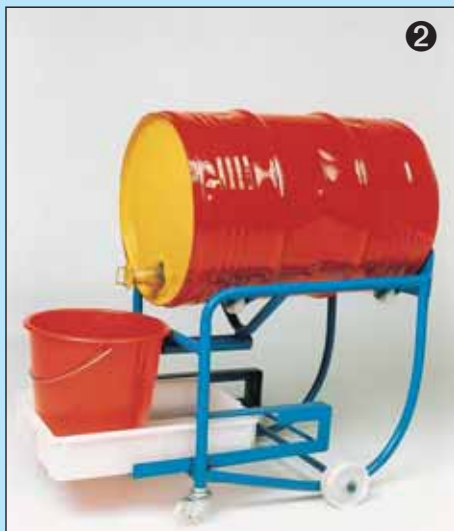

Barrel tilter for 50-/60 litre barrels



Barrel tilter for 50-/60 litre barrels with collector basin, vol. 100%

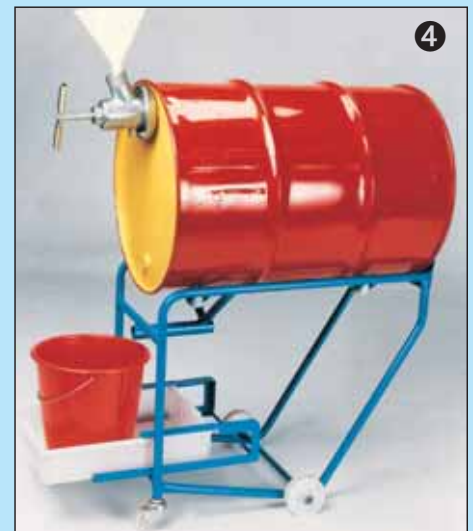

Barrel tilter for 100 litre barrels

**Accessories :**

| Type:                            | Art. no.      |  |
|----------------------------------|---------------|--|
| For barrel tilter of size:       |               |  |
| Lever rod with PVC grip 200 l    | <b>1032-0</b> |  |
| Lever rod with PVC grip 50/100 l | <b>1031-0</b> |  |

| Type:                                | Art. no.  |  |
|--------------------------------------|-----------|--|
| For barrel tilter of size:           |           |  |
| Plastic drip collector, 50/100/200 l | <b>KW</b> |  |
| Metal support rollers, 100/200 l     | <b>TR</b> |  |



**Barrel tilter with tank 1035-1**

## Barrel tilter

- with large tank  
100% collector volume
- Wheel set:  
2x solid-rubber wheels 200 mm Ø  
2 support legs
- Finish: paint colour RAL 5015

**Safe pollution-free storage and pouring of water-hazardous fluids.**

| Art. no. | Description  |
|----------|--|
| 1035-1   | Barrel tilter for 200 litre barrels with PVC barrel rollers, incl. collector tank (capacity 203 l) |
| TR       | Metal support rollers  |
| 1032-0   | Lever rod with PVC grip  |



**Barrel tilter with collector tank for 220 litre plastic barrels**

| Art. no. | Description   |
|----------|---|
| 1035-K   | Barrel tilter with collector tank, capacity 229 l, Wheel set of solid rubber, Ø 200 mm, Dimensions 650x1500 mm, pouring height 600 mm |
| 1032-0   | Lever rod with PVC grip   |

# Barrel boy

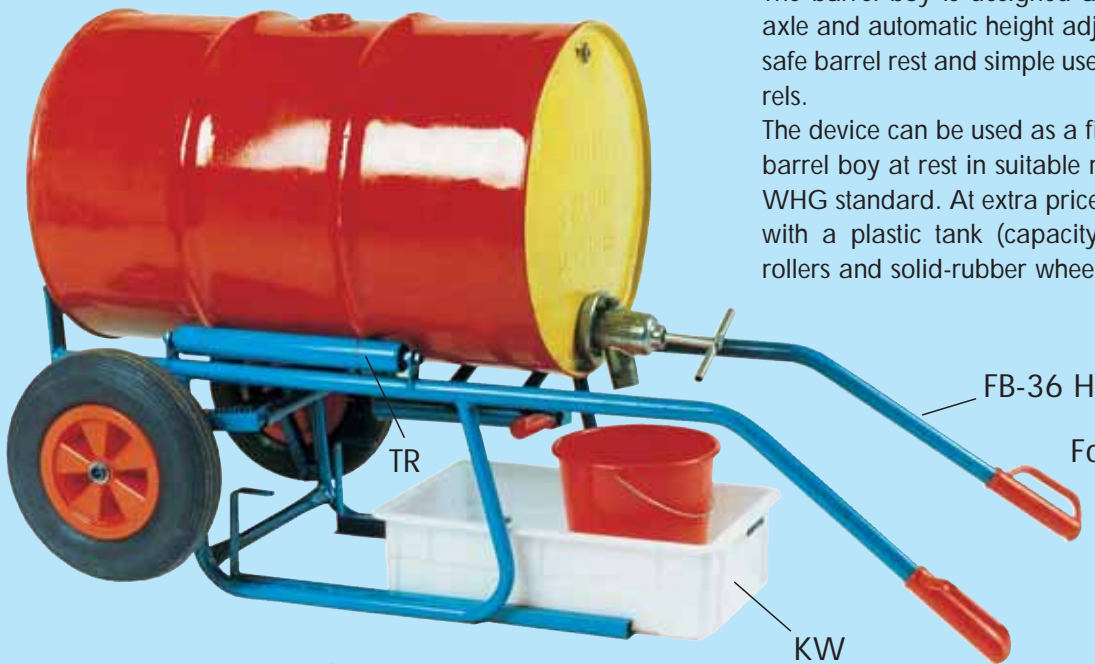

The ideal handling device for transport, storage and filling of 200-litre barrels.

The barrel boy is designed as a universal device with swing axle and automatic height adjustment. Its main features are its safe barrel rest and simple use as a means of transporting barrels.

The device can be used as a filling point simply by placing the barrel boy at rest in suitable rooms fitted with floor sealing to WHG standard. At extra price, the barrel boy can be supplied with a plastic tank (capacity 27 litres), with metal support rollers and solid-rubber wheels Ø 400 mm.

For transporting 200-litre barrels – optionally as filling point

With "swing axle" and automatic height compensation



## Barrel boy in travel position

Barrel trolley and tilter for combined use of 200-litre rolling hoops and channel drums with a max. load-bearing capacity of 400 kg. Push against barrel, engage arrester hook, tilt back and move off.

Finish: paint colour RAL 5015

| Art. no. | Description  |
|----------|--|
| FB 36 H  | Barrel boy, pneumatic tyres Ø 400 mm, Dimensions 800 x 1450 mm, pouring height 450 mm, |
| KW       | Plastic drip collector, capacity 27 l  |
| VG       | Solid-rubber wheels Ø 400 mm   |
| TR       | Metal support rollers Ø 50 mm  |

## Drum tilter

Constructed of welded steel tubing, coated, with permanent surface protection, impact and scratch proof with adjustable holding-down clamp Holder for 60-litre drum.

Design:

Paint colour RAL 5015

Width x length: 335 x 415 mm

W x H (in stand): 470 x 1250 mm

Length (in stand): 900 mm

Length (tilted): 1200 mm



| Art. no. | Type                                  |
|----------|---------------------------------------|
| 1028-3   | stationary                            |
| 1028-4   | mobile with polyamide wheels Ø 100 mm |



**Barrel roller** for all barrels up to 200 litres capacity, hot galvanized, 4 polyamide swivel rollers Ø 75 mm, inner Ø = 610 mm, Underclearance: 100 mm

**FAR-1:** closed type with tight-welded base, edge height: 80 mm

**FAR-2:** open type, edge type 30 mm

| Art. no. | Type      |
|----------|-----------|
| FAR-1    | with base |
| FAR-2    | open      |

## Barrel transporter for 60-litre plastic barrels - type "Barrelfix"



Barrel transporter type "Barrelfix" with narrow forks for picking up 60-litre plastic barrels.

**Design and function:** the barrel transporter with manual pushing grips, wheel set and pick-up forks is pushed against the top edge of the barrel, lifted and moved away. The barrel swings freely in the holder. Barrel pick-up: in standing position from the floor or from the pallet 150 mm high.

Finish: paint colour RAL 2000

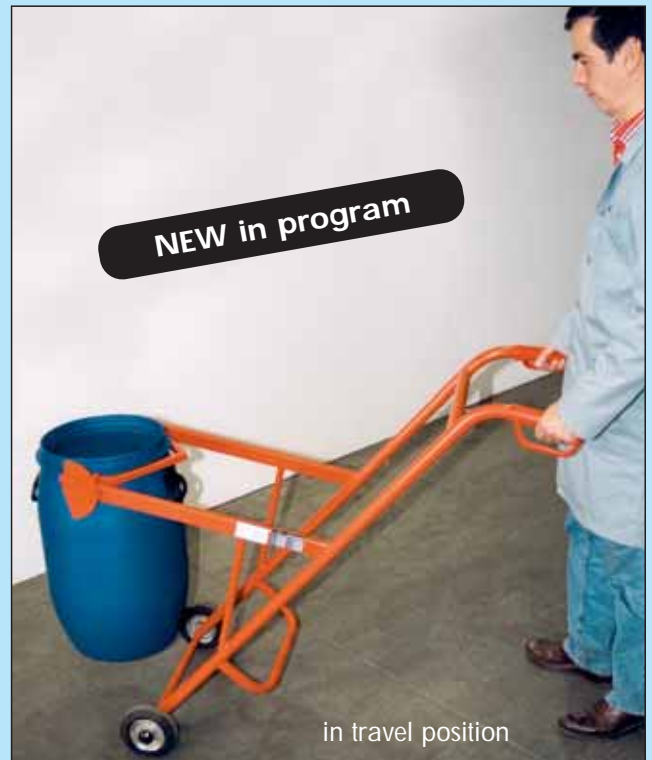

| Art. no. | Description   |
|----------|---|
| FA-F     | Barrel transporter "Barrelfix"<br>Wheel set: 2 x Ø 120 mm<br>Solid rubber |



## Hydraulic barrel tilter "Universal"

The hydraulic barrel tilter "Universal" max. load 300 kg, with roller rests for 200-litre barrels (height-adjustable) and with forks for pushing under the barrel, is suitable for filling barrels with carefully calculated quantities. It can also be supplied with a working and installation platform 800 x 1000 mm as required. The hydraulic system (with venting valve) for lifting and tilting by 90° is controlled manually. The barrel is lifted from the standing position on floor or on pallet.

Finish: paint colour RAL 5015



| Art. no. | Description  |
|----------|--|
| H-FK 300 | Hydr. tilter "Universal" for 200-litre barrels   |
| H-FK 301 | Hydr. tilter "Universal" for 200-litre barrels with working and installation table               |
|          | Wheel set: 2 x swivel wheels 140 mm Ø solid rubber<br>2 x lift-truck wheels 80 mm Ø solid rubber |



# Barrel transporter (lifter) for 200-litre steel barrels with V-angle chassis



Pick-up from ground



With chassis over pallet



Bracketing position

## Model LB 301 / 302 with V-angle chassis

**Wheel set:**

2 x swivel wheels, solid rubber D = 140 mm with total brake  
2 x fixed wheels, solid rubber

**Description:**

The newly designed barrel transporter, model LB 301 / 302 is fitted with an automatic clamping device for the top edge of the barrel or the body of the barrel. It is suitable for gripping 200-litre barrels. The V-angle chassis can be pushed over the Europallet or the pallet can be approached diagonally from one of its corners. The barrel can be picked up from the ground or from a pallet (see fig. above).

The lifting height from the floor to the bottom edge of the barrel is 550 mm.

Finish: paint colour RAL 2000

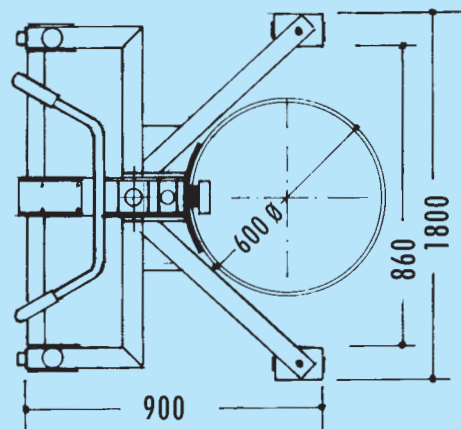

Model LB 301 with automatic clamp for top edge of barrel

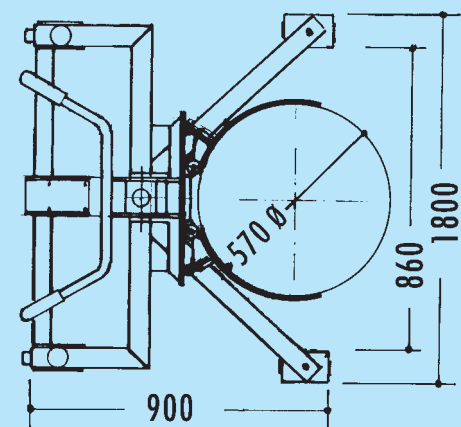

Model LB 302 with automatic clamp for body of barrel

| Technical data   |                      |
|--|----------------------|
| <b>Art. no. LB 301</b> with V-angle chassis and automatic clamp for top edge of barrel |                      |
| <b>Art. no. LB 302</b> with V-angle chassis and automatic clamp for body of barrel     |                      |
| Max. load  | 300 kg               |
| Lift height  | 550 mm               |
| Height of V-angle chassis  | 180 mm               |
| Dimensions L x W x H (retracted)   | 900 x 1080 x 1400 mm |
| Height (extended)  | 1950 mm              |

## Barrel transporter (lifter) for 200-litre steel barrels with automatic clamp for top edge of barrel



LB-300 PA-E



LB-300 PA

### Model LB 300 PA-E

with chassis passing under object

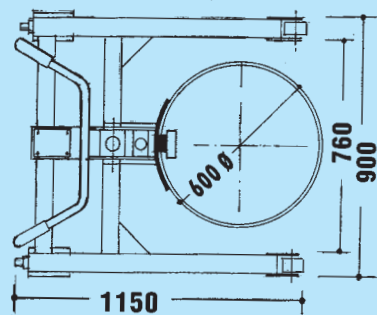

Wheel set:  
2 x polyamide wheels  
80 mm Ø  
2 x swivel wheels/  
solid rubber  
140 mm Ø  
with total brake

### Model LB 300 PA

with chassis passing over Europallets

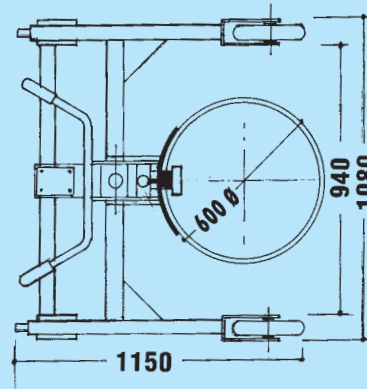

Wheel set:  
2 x solid rubber wheels  
250 mm Ø  
2 x swivel wheels/  
solid rubber  
140 mm Ø  
with total brake

Model LB 300 PA-E with chassis moving beneath object is especially suitable for loading containers, shelves and barrel pallets.

### Function / Operation

For easy moving and lifting of 200-litre barrels onto pallets or collector tanks. Barrels resting on the ground are clamped and held safely by the automatic clamping device. The barrel is then lowered and released by means of the manual lever. The barrel is lifted by means of the pump lever on the hydraulic pump. The lowering process is precisely controlled by the venting valve.

All models are fitted with solid-rubber wheels. The swivel wheels are fitted with total brakes. The standard hydraulic lifting stroke is 550 mm. Maximum stroke in special models, 1200 mm.

Finish: paint colour RAL 2000

| Technical data                        |                |                |                |
|---------------------------------------|----------------|----------------|----------------|
| Art. no.                              | LB 300 PA-E    | LB 300 S01     | LB 300 S02     |
| Type with chassis moving under object |                |                |                |
| Max. load                             | 300 kg         | 300 kg         | 300 kg         |
| Lift height                           | 550 mm         | 900 mm         | 1200 mm        |
| Chassis height                        | 80 mm          | 80 mm          | 80 mm          |
| Dimensions L x H                      | 1150 x 1400 mm | 1150 x 1750 mm | 1150 x 2050 mm |

| Technical data                        |                |                |
|---------------------------------------|----------------|----------------|
| Art. no.                              | LB 300 PA      | LB 300 PA-H    |
| Type with chassis passing over pallet |                |                |
| Max. load                             | 300 kg         | 300 kg         |
| Lift height                           | 550 mm         | 550 mm         |
| Chassis height                        | 160 mm         | 410 mm         |
| Dimensions L x H                      | 1150 x 1350 mm | 1100 x 1400 mm |

# Barrel transporter (lifter) with automatic clamp for barrel body



**Model LB 300 PA-E/V**

with chassis passing beneath object



**Model LB 300 PA/V**

with chassis passing above Europallet

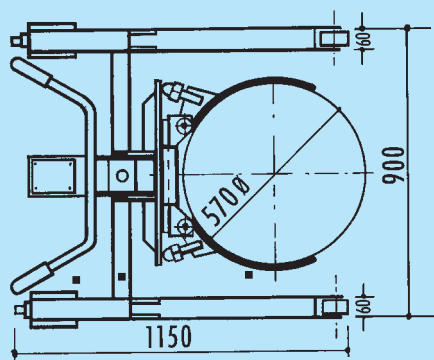

Wheel set:  
 2 x polyamide wheels  
 80 mm Ø  
 2 x swivel wheels/  
 solid rubber  
 140 mm Ø  
 with total brake

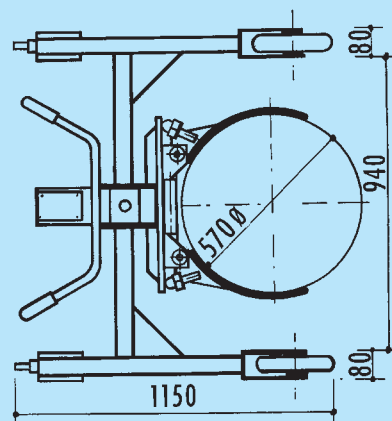

Wheel set:  
 2 x solid rubber wheels  
 250 mm Ø  
 2 x swivel wheels/  
 solid rubber  
 140 mm Ø  
 with total brake

## Function / operation

The barrel transporter in the starting position is pushed against the barrel and is then clamped automatically, i.e. the grab arms open diagonally upwards due to the pressure exerted. They drop back as soon as they have passed the middle of the barrel. The barrel is lifted by means of the manual hydraulic pump and can be transported safely. The barrel is released automatically when it is lowered. The barrel transporter is then pulled back.  
 Finish: paint colour RAL 2000

| Technical data   |        |
|--|--------|
| <b>Art. no. LB 300 PA-E/V</b><br>with chassis passing under object |        |
| Max. load approx.  | 300 kg |
| Lift height  | 550 mm |
| Weight approx.   | 75 kg  |

| Technical data  |        |
|---|--------|
| <b>Art. no. LB 300 PA/V</b><br>with chassis passing over pallet |        |
| Max. load approx.   | 300 kg |
| Lift height   | 550 mm |
| Chassis height  | 180 mm |
| Weight approx.  | 75 kg  |

## Multi-purpose barrel grab - tested for safety -



Engagement of barrel in upright position

### For 200-litre steel barrels, horizontal or upright

For 200-litre steel barrels on their side or upright with or without locking device. The extendable turning claws with push-in connection can be adapted for the specific purpose intended. The multi-purpose barrel grab is suspended from a load hook.

Max. load: 400 kg.  
Finish: paint colour RAL 2000



Engagement of barrel in horizontal position

| Art. no.         | Type                   |
|------------------|------------------------|
| <b>KOZ-40 H</b>  | without locking device |
| <b>KOZ-40 HA</b> | with locking device    |

## Barrel clamp



- Component: of high-strength steel
- Max. load = 500 kg

| Art. no.         | Type   |
|------------------|--|
| <b>KLE-50 H</b>  | with shackle   |
| <b>KLE-50 HK</b> | with shackle and chain harness with ring (600 mm long) |

## Grab with clamping claws

for plastic barrels

Finish: paint colour RAL 2000

**Design:**  
with 4-point clamping system  
Locking device and lever



- For standard lid barrels (capacity: 120 l)
- Manual operation

|                                   |                    |
|-----------------------------------|--------------------|
| Holder Ø = 395 mm/body Ø = 492 mm |                    |
| Max. load approx.                 | <b>Art. no.</b>    |
| 360 kg                            | <b>FSP-K1-36 H</b> |



- For L-ring barrels (capacity: 220 l)
- Manual operation

|                        |                    |
|------------------------|--------------------|
| Holder body Ø = 598 mm |                    |
| Max. load approx.      | <b>Art. no.</b>    |
| 360 kg                 | <b>FSP-K2-36 H</b> |

## Loading hook

Position one truck fork in the centre. Lift loading hook and tighten butterfly nut. Finish: paint colour RAL 2000

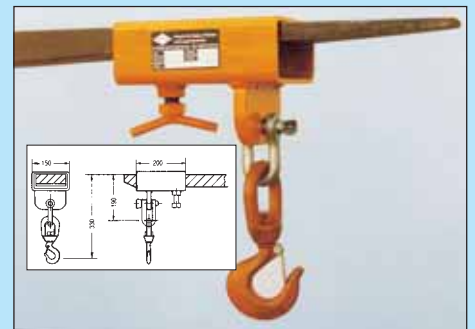

| Dimensions: WxHxL: 150 x 75 x 200 mm |                                 |   |
|--------------------------------------|---------------------------------|---|
| Max. load                            | <b>Art. no.</b><br>with shackle | <b>Art. no.</b><br>with shackle and rotating hook |
| 2000 kg                              | <b>2003</b>                     | <b>2004</b>                                       |

## Load beam for truck forks

Finish: paint colour RAL 2000

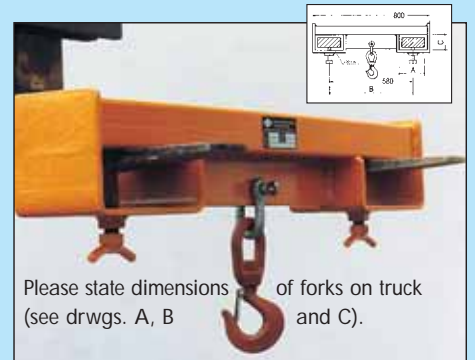

|           | <b>Art. no.</b><br>with shackle | <b>Art. no.</b><br>with shackle and rotating hook |
|-----------|---------------------------------|---|
| Max. load |                                 |   |
| 2000 kg   | <b>2001</b>                     | <b>2002</b>                                       |
| 3000 kg   | <b>3001</b>                     | <b>3002</b>                                       |
| 4000 kg   | <b>4001</b>                     | <b>4002</b>                                       |
| 5000 kg   | <b>5001</b>                     | <b>5002</b>                                       |



## Barrel grab with clamping claw

- For 200-litre roll-hoop or channel drums
- Manual operation
- For open and closed steel-bodied barrels

### Design:

With 4-point clamping system locking device and hand lever

Paint colour RAL 2000

|                     |                 |
|---------------------|-----------------|
| Barrel Ø 570-590 mm |                 |
| Max. load approx.   | <b>Art. no.</b> |
| 360 kg              | <b>FSP-36 H</b> |

- For lifting upright barrels -

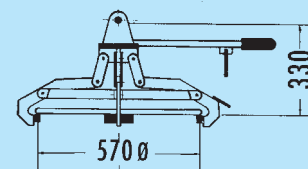

## Barrel grab with band

- For 200-litre roll-hoop or channel drums
- Manual operation

### Design:

with toggle-lever clamp  
with fine-adjustment device  
chain harness and suspension ring

Paint colour RAL 2000

|                     |                 |
|---------------------|-----------------|
| Barrel Ø 570-590 mm |                 |
| Max. load approx.   | <b>Art. no.</b> |
| 600 kg              | <b>BG-600 H</b> |

- For lifting upright barrels -

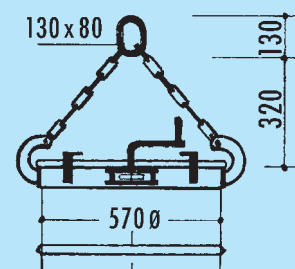

## Barrel clamp

- For closed 200-litre barrels
- For 200-litre roll-hoop or channel drums
- Manual operation

### Design:

with suspension ring for load hook,  
grab arm with holding claws, hand grip etc.

Paint colour RAL 2000

|                     |                 |
|---------------------|-----------------|
| Barrel Ø 570-590 mm |                 |
| Max. load approx.   | <b>Art. no.</b> |
| 400 kg              | <b>FKL-40 H</b> |

- For lifting upright barrels -

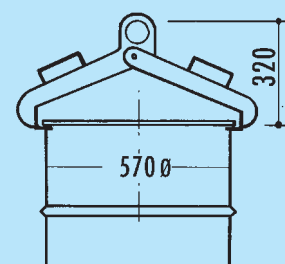

## Barrel-edge grab with clamping claw

- For 200-litre roll-hoop or channel drums
- Manual operation

### Design:

with safety locking claw,  
shackle for load hook  
Paint colour RAL 2000

|                     |                   |
|---------------------|-------------------|
| Barrel Ø 570-590 mm |                   |
| Max. load approx.   | <b>Art. no.</b>   |
| 500 kg              | <b>FSP-R-50 H</b> |

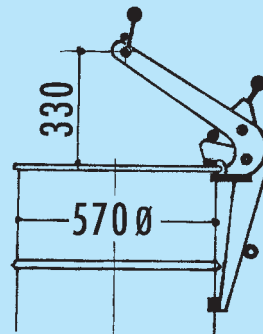

-For lifting upright or horizontal barrels-



## Barrel grab

- For 200-litre roll-hoop or channel drums
- Manual operation

### Design:

Scissor-type design,  
with non-slip rubberised grab pads,  
Locking device with manual lever  
Paint colour RAL 2000

|                            |                 |
|----------------------------|-----------------|
| Barrel body Ø 570-590 mm   |                 |
| Max. holder length, 900 mm |                 |
| Max. load approx.          | <b>Art. no.</b> |
| 360 kg                     | <b>FST-36 H</b> |

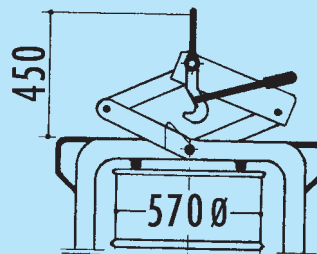

- For lifting upright barrels-



## Barrel pincer grab

- For 200-litre roll-hoop and channel drums
- Manual operation

### Design:

with suspension ring for load hook,  
Locking device with manual lever  
Paint colour RAL 2000

|                           |                 |
|---------------------------|-----------------|
| Lifting Ø for all barrels |                 |
| Lifting length 760-910 mm |                 |
| Max. load approx.         | <b>Art. no.</b> |
| 360 kg                    | <b>FZ-36 H</b>  |

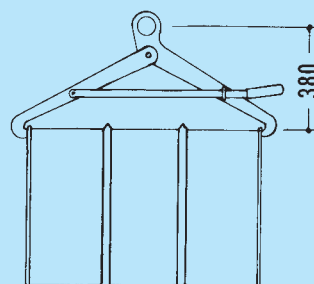

- For lifting barrels on their sides-





### Heavy-duty tilting beams

For 200-litre heavy-duty barrels, max. load 1200 kg

**Barrel holder:**

with safety console, spindle / clip band closure and height-adjustable claw lock with spring bolt  
Possible tilting angle for barrel: 360°.

**Design:**

with contrate worm-gear mechanism, manual wheel and wheel handle. Alternative: chain hoist, 2,0 m dangling  
Paint colour RAL 2000

|                                   |                 |
|-----------------------------------|-----------------|
| Max. load approx.                 | 1200 kg         |
| Barrel body Ø 570 mm              |                 |
| -with hand wheel and wheel handle | FKT-SO 1,2 H/HR |
| -with chain hoist                 | FKT-SO 1,2 H/HK |



### Tilting barrel grab

for upright barrels or barrels on their sides

**Barrel holder:**

automatic pick-up by lifting and fixing the height-adjustable legs fitted with rollers. Tilting barrel holder with ring for load hook, with anti-slip grab pads and mounted worm-gear mechanism with hand wheel, optional chain hoist, dangling 2.0 m.  
Paint colour RAL 2000

|   |             |             |
|---|-------------|-------------|
| Max. load approx.   | 250 kg      | 400 kg      |
| Barrel body Ø 570 mm  |             |             |
| Dimensions: from centre of rotating axis to bottom edge of lifting ring approx. 1.250 m |             |             |
| -with hand wheel and wheel handle   | FKG-25 H/HR | FKG-40 H/HR |
| -with chain hoist   | FKG-25 H/HK | FKG-40 H/HK |



### Tilting barrel grab

for upright barrels or barrels resting on their sides with manual turning device

**Barrel holder:**

automatic pick-up by raising and fixing the height-adjustable rests fitted with rollers.  

- for 200-litre roll-hoop or channel drums
- precise emptying by hand
- Max. turning range of barrel: 180°
- Finish: paint colour RAL 2000

|  |            |             |
|--|------------|-------------|
| Max. load approx.  | 250 kg     | 400 kg      |
| Barrel body Ø 570 mm   |            |             |
| Dimensions: from centre of rotating axis to bottom edge of lifting ring approx. 1.250 mm |            |             |
| Art. no.   | FKG-I 25 H | FKG-II 40 H |



### Barrel-tilting beam

-for fork-lift / hook

- For plastic and steel barrels
- For upright barrels with a Ø of 380-600 mm and 900 mm in height
- Manual operation by hand wheel or chain hoist, 2,0 m dangling
- Max. turning range of barrel: 360°
- With engaging rings for load hook or fork-lift pockets as required
- Worm gear, self-locking and maintenance-free

With holder box and height-adjustable safety lock for barrels of different sizes. Finish: paint colour RAL 2000

| Type without fork-lift pockets    |                 |                 |
|-----------------------------------|-----------------|-----------------|
| Max. load                         | 250 kg          | 400 kg          |
| -with hand wheel and wheel handle | FKT-K 25 H/HR   | FKT-K 40 H/HR   |
| -with chain hoist                 | FKT-K 25 H/HK   | FKT-K 40 H/HK   |
| Type with fork-lift pockets       |                 |                 |
| Dimensions: 140 x 60 mm           |                 |                 |
| Distance between forks            |                 |                 |
| Centre-centre = 470 mm            |                 |                 |
| Max. load                         | 250 kg          | 400 kg          |
| -with hand wheel and wheel handle | FKT-K 25 H-G/HR | FKT-K 40 H-G/HR |
| -with chain hoist                 | FKT-K 25 H-G/HK | FKT-K 40 H-G/HK |



### Barrel tilting beam

with "pneumatic" turning mechanism. Also available as explosion-proof type to guidelines 94/9/EG  
 - ATEX 95-Zone 2 available  
 - Available on request-

- Max. turning range of barrel: 360°
- Manual operation by control slide

Beam with ring for load hook, mounted worm-gear mechanism with DRL-Motor 25 M2, self-locking.  
Required pressure = 6 bar

**Barrel holder:** bands, rubberised on inside, riveted into position, with height-adjustable safety locking system, holding claws and spring bolt. Finish: paint colour RAL 2000

**Lock:** ratchet-lock strap

|                           |               |
|---------------------------|---------------|
| Max. load approx.         | 400 kg        |
| Barrel body Ø 570 mm      |               |
| Art. no.                  | FKT-P 40 H    |
| in explosion-proof design | FKT-P 40 H/EX |
| 2 fork-lift pockets       |               |

## Barrel turner

as fork-lift add-on unit for sideways emptying of barre

- For 200-litre roll-hoop or channel drums
- Precise emptying at any height
- Easy operation with hand wheel or 2,0-meter dangling endless chain
- Rotatable to 360° - finish: paint colour RAL 2000

|                                    |             |
|------------------------------------|-------------|
| Load capacity                      | 360 kg      |
| Barrel-body Ø                      | 570 mm      |
| Cross-section of fork-lift pockets | 200 x 90 mm |
| Fork distance, centre-centre       | 510 mm      |
| Fork length                        | 800 mm      |
| - with hand wheel and wheel handle | FA-W/HR     |
| - with chain hoist                 | FA-W/HK     |

- The grab pads are extended for 200-litre lid barrels with smooth body Barrel turner
- Lock: 2 ratchet-lock straps



## Adjustable beam - fork-lift / load hook -

- For barrels with Ø 380-600 mm x 900 mm in height
- For plastic barrels of special type on request
- Manual operation by hand wheel or chain hoist

Adjustable beam (type "Spannfix") with ring for load hook or fork-lift pockets as required, complete with height-adjustable rests fitted with rollers, suitable for lifting steel barrels in vertical or horizontal positions with diameters of between 380 and 600 mm and maximum height of 900 mm. They are clamped into position by operating the adjusting spindle with hand wheel and safety lock. The precise turning movement (max. 360°) is executed by turning the worm-gear mechanism with hand wheel or by optional dangling 2,0 m chain hoist. Finish: paint colour RAL 2000

| Type without fork-lift pockets                |               |               |
|---|---------------|---------------|
| Max. load                                     | 250 kg        | 400 kg        |
| - with hand wheel and wheel handle            | VKT-25 H/HR   | VKT-40 H/HR   |
| - with chain hoist                            | VKT-25 H/HK   | VKT-40 H/HK   |
| Type with fork-lift pockets                   |               |               |
| Dimensions: 200 x 75 mm                       |               |               |
| Distance between forks centre-centre = 440 mm |               |               |
| Max. load                                     | 250 kg        | 400 kg        |
| - with hand wheel and wheel handle            | VKT-25 H-G/HR | VKT-40 H-G/HR |
| - with chain hoist                            | VKT-25 H-G/HK | VKT-40 H-G/HK |



Beam suspension system:  
with fork-lift truck or crane

## Barrel-tilting beam

- For upright 200-litre roll-hoop or channel drums, barrel-body Ø 570 mm
- Precise emptying
- Manual operation by hand wheel or chain hoist
- Max. turning range of barrel: 360°

Beam with suspension ring for load hook or with fork-lift pockets, mounted worm-gear mechanism with hand wheel or with dangling 2,0-metre chain hoist, fully maintenance-free and self-locking.

**Barrel holder:** with bands, rubberised on inside and riveted into position.

**Lock:** ratchet-lock strap

Finish: paint colour RAL 2000

| Type without fork-lift pockets                |               |               |
|---|---------------|---------------|
| Max. load                                     | 250 kg        | 400 kg        |
| -with hand wheel and wheel handle             | FKT-25 H/HR   | FKT-40 H/HR   |
| -with chain hoist                             | FKT-25 H/HK   | FKT-40 H/HK   |
| Type with fork-lift pockets                   |               |               |
| Dimensions: 150 x 75 mm                       |               |               |
| Distance between forks centre-centre = 470 mm |               |               |
| Max. load                                     | 250 kg        | 400 kg        |
| -with hand wheel and wheel handle             | FKT-25 H-G/HR | FKT-40 H-G/HR |
| -with chain hoist                             | FKT-25 H-G/HK | FKT-40 H-G/HK |



Turning gear:  
maintenance-free,  
self-locking



## Barrel tilter for mounting on fork-lift trucks

### Design features:

- For upright 200-litre roll-hoop or channel drums
- Type with holding box for steel and plastic barrels (art. no. FKT-ST-K)
- Holding frame with fork-lift pockets
- Emptying at any height
- Manual operation by hand wheel or endless chain (2,0 m dangling)
- Worm-gear mechanism laterally mounted, self-locking and maintenance-free with protective housing
- Safe lifting of barrel with bands, rubberised on interior with spindle lock
- Secured by chain to prevent slipping off forks
- Max. turning range of barrel: 360°
- Finish: paint colour RAL 2000



Design for steel und plastic barrels

| Model              | without holding box | with holding box |
|--------------------|---------------------|------------------|
| Max. load          | 400 kg              | 400 kg           |
| Barrel Ø           | 570 mm              | 380/600mm        |
| Fork pockets i/Li. | 170 x 70 mm         | 170 x 70 mm      |
| For distance i/Li. | 690 mm              | 690 mm           |
| with hand wheel    | FKT-ST 40 HR        | FKT-ST-K 40 HR   |
| with chain hoist   | FKT-ST 40 HK        | FKT-ST-K 40 HK   |

## Barrel turner for mounting on fork-lift truck with a max. load of 400 kg

Suitable for holding steel and plastic barrels with a Ø of 400-600 mm and max. height 1000 mm.

### Barrel pick-up device:

Cradle-shaped with base plate, complies with new safety regulations to UVV or EU guidelines (CE declaration).

### Lock:

by ratchet-lock strap and height-adjustable locking with spring bolt.

The barrel turner with fork-lift pockets is fitted with 2 x 12 V starter batteries, charger, control unit with main switch and electric drive system for turning movement with DC motor 24 V 0,55 kW, controlled via a trailing cable with control bulb.

Price on request! !



## Barrel grab

The practical add-on unit for fork-lift trucks with re-designed grab head / automatic grab system

### Description:

The barrel grab type "GREIFFIX" for fork-lift trucks is produced by MEILLER with a newly designed clamping system and is suitable for the versatile handling of upright barrels under rugged conditions. This add-on device for fork-lift trucks is recommended for handling large numbers of barrels (e.g. in production industry, seaports, chemical processing etc.) They are already in frequent use for the loading and unloading of trucks, barrel-storage containers, Euro and chemical pallets and many other purposes.

### Function:

The "GREIFFIX" unit is positioned under the edge of the full upright barrel. The automatic clamping system closes and the barrel is lifted. The automatic clamping system releases the barrel when it is placed back on the ground.

### Design:

- Complete with chain-securing device
- Chassis: paint colour RAL 2000
- Grab head with clamping system: galvanised

## Type „GREIFFIX“

### Fork-lift add-on device

- For 200-litre channel drums and lid barrels or 220-litre ring plastic barrels (please state exact application)



### Technical data:

| Art. no. FAS-40 H-1                    |             | Art. no. FAS-80 H-2                    |             |
|--|-------------|--|-------------|
| Max. load                              | 400 kg      | Max. load                              | 800 kg      |
| Dimensions of fork-lift pockets        | 170 x 80 mm | Dimensions of fork-lift pockets        | 170 x 80 mm |
| Distance between forks centre - centre | 400 mm      | Distance between forks centre - centre | 400 mm      |
| Entry depth of fork-lift pockets       | 1000 mm     | Entry depth of fork-lift pockets       | 1000 mm     |
| Width of fork-lift pockets             | 580 mm      | Width of fork-lift pockets             | 580 mm      |
| Total width                            | 580 mm      | Total width                            | 980 mm      |
| Weight                                 | 78 kg       | Weight                                 | 108 kg      |

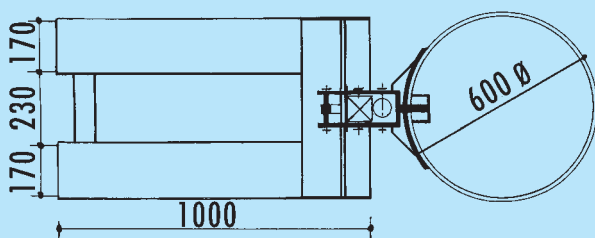

**Model FAS-40 H-1**  
for lifting 1 barrel  
Max. load: 400 kg

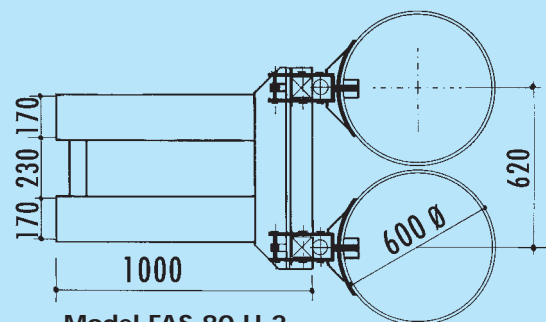

**Model FAS-80 H-2**  
for lifting 2 barrels  
Max. load: 800 kg

# Barrel grab

- add-on unit for fork lift -

- For 200-litre roll-hoop and channel drums
- With automatic locking system
- Model FA-M-1 for lifting 1 barrel
- Model FA-M-2 for lifting 2 barrels
- Grasps barrel by contacting the full barrel



### Description:

The barrel grabs of type FA-M-1 and FA-M-2 are mounted on the forks of the truck and locked in position with the wheel handle. The full 200-litre barrel is lifted by contacting the barrel body with the grab just beneath the centre channel or roll hoop. The pressure causes the grab arms to open diagonally upwards. As soon as they pass the centre of the barrel, they drop back and secure the barrel automatically. The truck driver then raises the barrel grab and the barrel rests securely locked in the grab arms.

The barrel is then deposited or removed in the reverse order.

Finish: paint colour: RAL 2000



Model FA-M-2

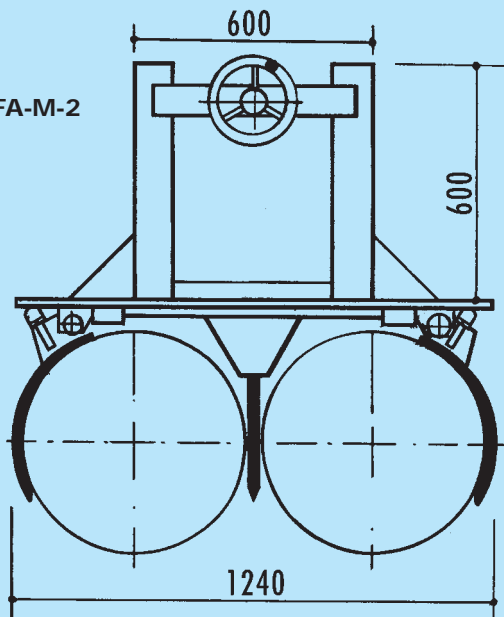

Model FA-M-1

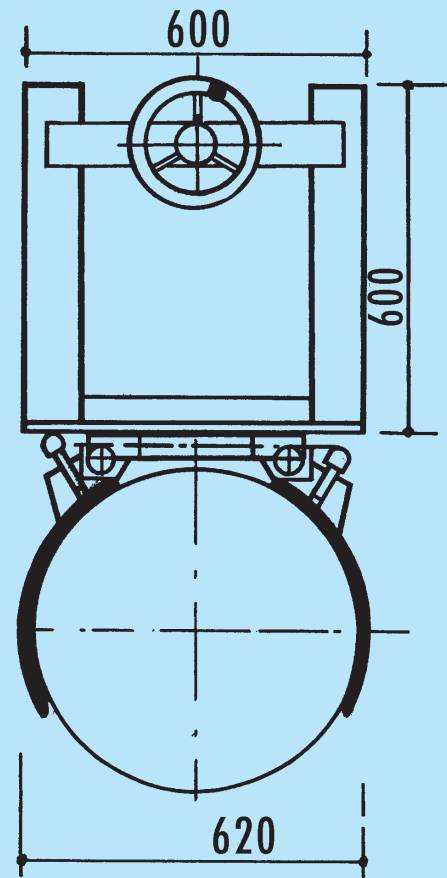

### Technical data:

| Art. no. FA-M-1                           |        | Art. no. FA-M-2                           |         |
|---|--------|---|---------|
| For lifting 1 barrel                      |        | For lifting 2 barrels                     |         |
| Max. load approx.                         | 600 kg | Max. load approx.                         | 800 kg  |
| Total width of fork-lift pockets approx.  | 600 mm | Total width of fork-lift pockets approx.  | 600 mm  |
| Total length of fork-lift pockets approx. | 600 mm | Total length of fork-lift pockets approx. | 600 mm  |
| Total width approx.                       | 620 mm | Total width approx.                       | 1240 mm |
| Weight approx.                            | 75 kg  | Weight approx.                            | 85 kg   |

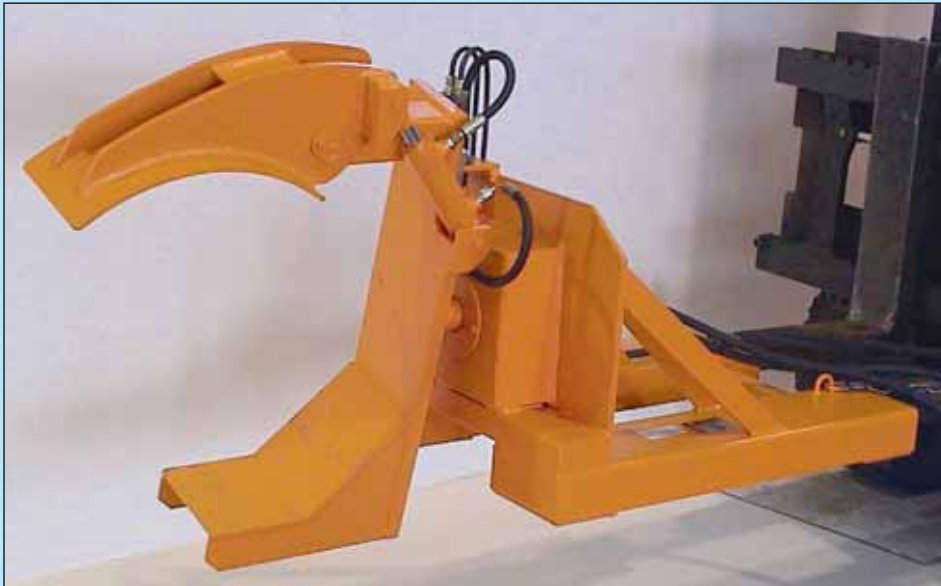

## Barrel-grab and rotating device

Hydraulic-powered, for mounting on fork-lift

*The practical add-on unit*

The hydraulic barrel grab and rotating device has been specially developed for mounting on a fork-lift truck. All the parts required for the unit are supplied by the manufacturer, i.e. connections for hydraulic pipes and hoses / plug-in connections etc. The control valve however must be supplied by the customer (mounted on fork-lift). The rotating gear and hydraulic unit are encased for protection and comply with TÜV guidelines.

Finish: paint colour RAL 2000

|   |          |
|---|----------|
| <b>Art. no. FAG-40 H</b>  | Max.load |
| Fully hydraulic with grab and rotating device, suitable for 200-litre barrels | 400 kg   |

### Model: FAG-40 H

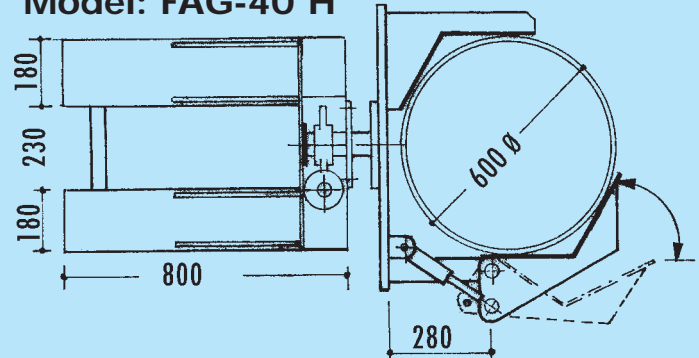

Controlled from the fork-lift with an additional 4-way control block.

## Barrel grab FRB

**Controlled from the fork-lift with an additional 4-way control block.**

Barrel grab FRB for grasping upright 200-litre barrels and placing them horizontally in store. Add-on unit for fork-lift for placing 200-litre barrels in barrel-storage shelves. Operation: the add-on unit grasps the upright barrel and deposits it in the store in the horizontal position. The automatic locking device allows the barrel to be placed in store on its side.

Finish: paint colour RAL 2000



| Technical data  |            |
|-----------------|------------|
| <b>Art. no.</b> | <b>FRB</b> |
| Max. load       | 300 kg     |
| Length::        | 1700 mm    |
| Width:          | 1025 mm    |
| Height:         | 700 mm     |

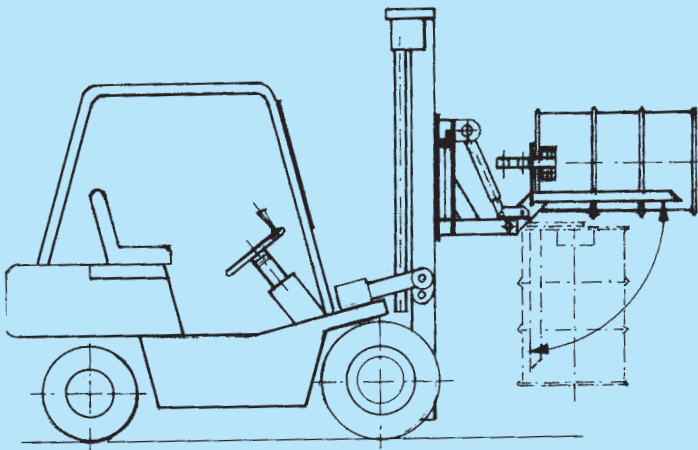

## Barrel manipulator Model FM-2 for mounting on fork-lift truck

- For lifting and transporting upright and horizontal 200-litrebarrels
- For loading and storing barrels in barrel shelves, filling points, shelf containers, hazardous-material pallets, collecting points, barrel-handling areas etc.
- Fully hydraulic function with additional 4-way control valve, with control block and opening for access to truck hydraulics, operated manually
- Fast installation and removal of manipulator in installation console of truck with bolted connection
- Finish: paint colour RAL 2000

### Engaging plate

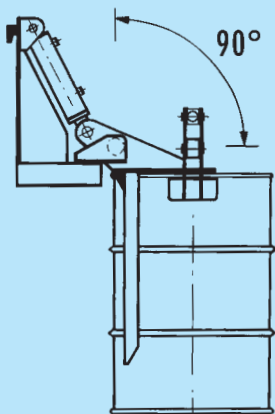

| Technical data:                |         |
|--------------------------------|---------|
| Art. no.                       | FM-2    |
| Max. load                      | 400 kg  |
| Weight approx.                 | 160 kg  |
| Projection with sloping forks  | 750 mm  |
| Projection with extended forks | 1240 mm |
| Overall width                  | 750 mm  |

Model FM-2 for mounting on fork-lift hydraulic system by rapid-action coupling

### Description:

The full barrel is lifted from the upright position by contact with the manipulator, then lowering the slide with the manipulator to the height of the barrel and clamping it by operating the control valve "CLOSE". The barrel is now firmly clamped on the barrel forks with holder and can be handled as required.



**Adjustable beam**  
for boiler  
with worm gear and hand wheel

*Special types*



**Barrel-tilting beam with electric drive**



**Adjustable beam**  
for storage container  
with electric drive system

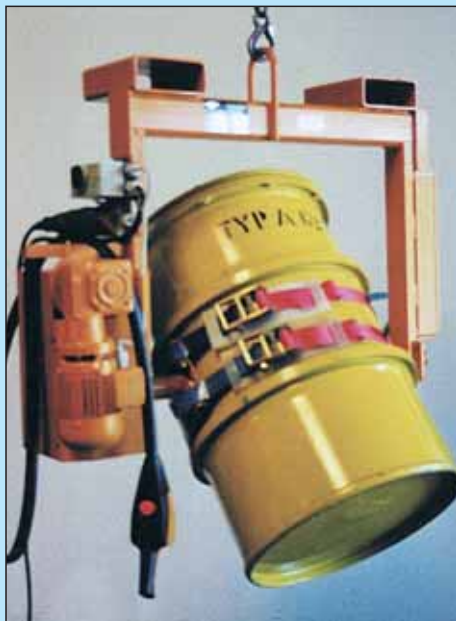

**Lifting load:**  
by crane or fork-lift truck

**Price on request**



**Load beams designed specifically for disposal drums – Max. load: 1,2 to.**

- **Barrel holder:**  
with barrel bands and ratchet-lock straps  
optional with insert box and base  
Lock with clamp band, spindle and hand wheel

- **Drive system:**  
with heavy-duty worm -type spur-wheel gear, self-locking and maintenance-free with electrical attachment gear  
Power 0,55 kW,  
voltage 220-240/380-415 V

- **Control system:**  
Motor-protection switch and control bulb with optional push button (watchdog circuit)

# Barrel mixing devices, electrically powered

for solid and liquid substances in barrels and containers with a Ø of 560/600 mm

### Barrel mixing devices of type:

- with chassis wheel Ø 400 mm (solid rubber) and stand skids
- Holding cradle with twin barrel rollers of vulcanised rubber Ø 125 mm, ideal for thin-walled barrels
- Drive axle mounted on maintenance-free bearings, driven by 1 x with chain-wheel transmission to spur-wheel back-geared motor  
1 x as loose drive unit on the opposite side
- Drive unit fixed permanently to leg of mixer, consisting of a spur-wheel back-geared motor, power 0,37 kW, Motor voltage 220-242/380-420 V, 50 Hz, IP 44
- Barrel rotation = 8,5 R.p.m., or as required
- Control system:  
for **one** direction with ON-OFF motor-protection switch  
for the **left-right** direction with reversing protection via push button, optional reversing switch
- Push-in safety housing, 2-parts with limit switch to UVV to UVV (see detail drawing)
- Function: the mixing process can start only when the 2 side safety elements are locked into position.
- Finish: paint colour RAL 5015



Barrel mixing unit, art. no. FB-36H/1+2

### Function unit:

also available without push-in safety housing!  
Safety housing -push-in system-

Max. load: 300 kg

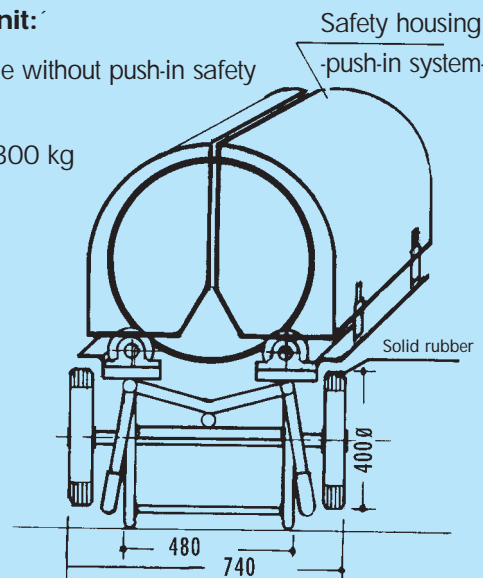

| Art. no.       | Description   |
|----------------|---|
| FB-36 H/1      | Barrel mixing unit  |
| Control system | for <b>one</b> rotation direction with ON-OFF motor-protection switch |

| Art. no.       | Description  |
|----------------|--|
| FB-36 H/2      | Barrel mixing unit   |
| Control system | for <b>two</b> directions with left-right reversing protection |

| Art. no.       | Description  |
|----------------|--|
| FB-36 H/Ex     | Barrel mixing unit   |
| Control system | for <b>one</b> rotation direction with ON-OFF motor-protection switch in explosion-proof T3 Zone 2 to ATEX |

### Barrel rolling-frame mixer

Stationary with collector tank incl. strap and locking device.

Paint colour: RAL 5015

Electric drive: with gear motor and reverse-turn lock,

Power = 0,37 kW; Voltage = 220/380 V;

Control system: with ON-OFF motor-protection switch

Track-guided rolling frame Ø 130 mm: with adjustable spring-loaded tensioning rollers.

Barrel rotation = 6,5 r.p.m. or as required.

| Art. no. | Description                |
|----------|----------------------------|
| FR-M     | Barrel rolling-frame mixer |

As above but incl. explosion protection to guidelines 94/9/EG (Atex 95) with explosion-proof motor and switch devices. Zone 2 stainless-steel rollers with wheel flange (notch-impact tested)

| Art. no. | Description   |
|----------|---|
| FR-M-EX  | Barrel rolling-frame mixer, explosion-proof version |



Barrel rolling-frame mixer, art. no. FR-M

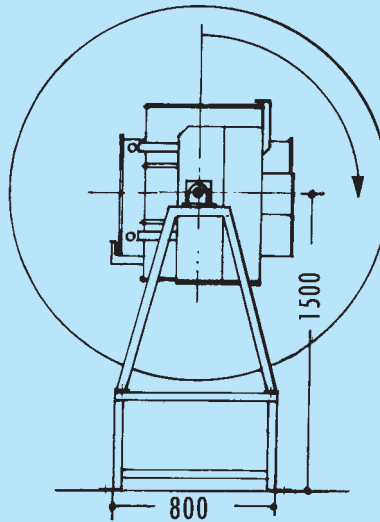

with safety grid

## Barrel mixing station manufactured to customer specification

with 2 loading stations in the form of cradles for holding 200-litre barrels, with optional replaceable inset for smaller barrels, containers or drums.

The loading stations are offset from one another by 90° to allow materials in liquid, granular or solid form to be mixed separately from one another.

**Drive:** with worm-gear motor and hollow shaft, power 1,5 kW, voltage 230/400 V delta / star.

**Control system:** manually controlled for the desired operations; located in control cabinet with main switch EMERGENCY STOP (acc. to UVV guidelines).

**Safety housing:** made to specification and dimensions required acc. to UVV.

**Note:** also available in explosion-proof version (EEX de II BT) acc. to ATEX 1109 Zone 2+1.

## LIFTING AND TURNING STACKER TRUCK

**Explosion-proof type to ATEX zone 2**

**Sturdy truck design for a max. load of 600 kg**



**Explosion-proof type** to guidelines 94/9/EG ATEX Zone 2 with pneumatic lifting cylinder, fully installed with one-way restrictor valve and manual distributing valve for height adjustment. .

**Chassis:** with electrically conductive running and swivel wheels.

**Turning gear unit:** with worm-gear transmission 1:80, mod. 3 of MS fixed permanently to turning unit with forks for load. The turning device (up to 360°) is operated by hand wheel.



## The safe way to stack barrels

The high-lift trucks have been specially developed for the safe stacking of barrels in stores. They are available in two types with a lift height (shelf entry height) of between 230 and 2200 mm.

### Design:

With push-under chassis, max. load 300 kg, distance between chassis bars 800 mm, height of chassis bars 85 mm. All MEILLER high-lift trucks comply with the regulations BGV for industrial transport trucks.

### Function:

In all models, the upright barrels are clamped manually by adjusting spindle with removable hand crank. The lifting movement and angle of turning jib are controlled by a manual or electric hydraulic system depending on model by means of a hand switching device.



for stacking shelves

## High-lift truck for 200-litre steel barrels.

| Art. no.  | Description   | Design               |
|-----------|---|----------------------|
| FRB-1/HI  | High-lift truck, manual-hydraulic lift, manual manoeuvring, lift height 1500 mm, chassis height 85 mm, chassis width 850 mm, Dimensions (L x H) 1420 x 1850 mm, max. load 300 kg with single mast | with single mast     |
| FRB-1/HII | High-lift truck, manual-hydraulic lift, see above, but incl.: lift height 2200 mm, dimensions (L x H) 1420 x 2550 mm  | with single mast     |
| FRB-1/H-T | High-lift truck, manual hydraulic lift see above, but incl.: lift height 2200 mm, dimensions (L x H) 1420 x 1950 mm   | with telescopic mast |
| FRB-2/EI  | High-lift truck, electrical hydraulic lift, manual manoeuvring, lift height 1500 mm, chassis height 85 mm, chassis width 850 mm, dimensions (L x H) 1420 x 1850 mm, max. load 300 kg              | with single mast     |
| FRB-2/EII | High-lift truck, electrical hydraulic lift, see above, but incl.: lift height 2200 mm, dimensions (L x H) 1420 x 2550 mm  | with single mast     |
| FRB-2/E-T | High-lift truck, electrical hydraulic lift, see above, but incl.: lift height 2200 mm, dimensions (L x H) 1420 x 1950 mm  | with telescopic mast |

## High-lift truck with telescopic mast in shelf-entry position



Type FRB-1/H-T

For electrically operated type  
-please enquire-

Type FRB-1/H-T



## High-lift truck with telescopic mast in tilt position.



Type FRB-1/HI

manual manoeuvring

## High-lift truck with single mast in barrel-lifting position.



With electric travel-drive, electrical-hydraulic lifting and turning device manually operated.



Manoeuvrable with electrical-hydraulic lifting and barrel-turning device manually operated

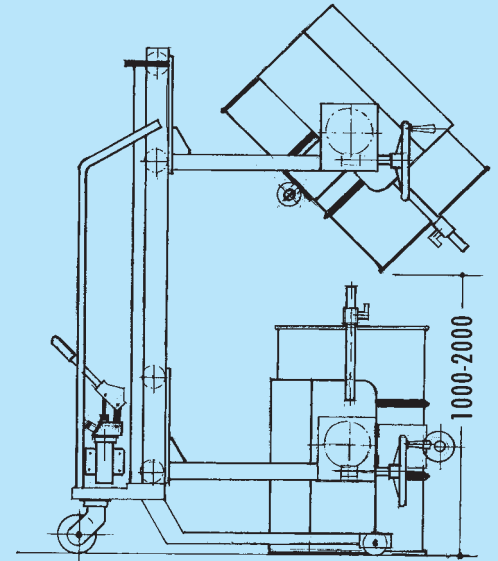

Manoeuvrable with manual-hydraulic lifting and barrel-turning device manually operated.

- For transporting barrels
- For emptying barrels with fluids of all types

## Barrel lifting and tilting device, type MHK-2500

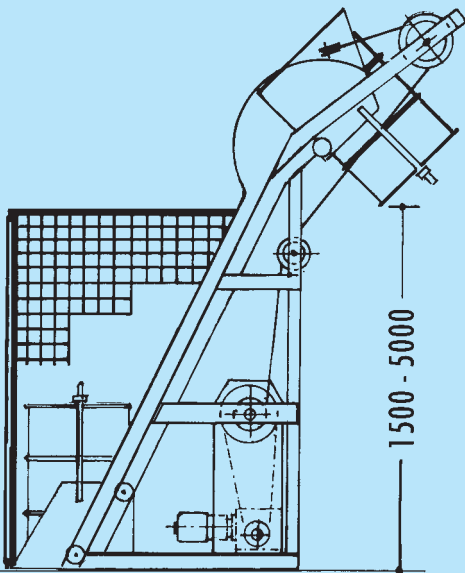

### Barrel lifting and tilting unit stationary type MHK-2500

**Lifting device:**

with electric drive  
with safety fencing  
incl. access doors  
acc. to TÜV guidelines

**Control system:**

with push-button watchdog and limit switch  
Max. load: 300 kg

### Barrel lifting and tilting device type MHK mobile or stationary with manual or electric drive

manufactured from strong structural-steel profiles depending on size, tipping height and max. load.

**Suitable for:**

- lifting steel and plastic barrels
- loading hoppers, containers and filling machinery

The upright barrels are fed in manually or automatically via conveyor system.

The tipping height can be varied from 1500 mm to 5000 mm (depending on requirement)



### Barrel lifting and tilting unit stationary with electric drive for storage containers

-please enquire-

Max. load: 300-1000 kg



**Barrel-storage system** - base unit with 2 storage levels, compartment load = 1920 kg, adjustable in height for storage of 4 horizontal and 6 vertical 200-litre barrels, with optional add-on unit for a total of 8 horizontal and 12 vertical barrels.

**Dimensions:**

Basic unit, W x T x H = 2862 x 1300 x 2500 mm

Add-on unit, W x T x H = 2786 x 1300 x 2500 mm

The units are supplied with collector tanks to WHG and General Construction Approval no. Z-38.5-168 for installation indoors, i.e. it must be ensured that the storage systems are installed only in open protected rooms with natural ventilation.

**We also supply the following accessories:**

- Galvanised grids for covering storage surfaces  
**Art. no. 1465**
- Barrel rests, fully extendable, galvanised, for loading by crane or fork lift truck  
**Art. no. 1072-H**
- Barrel rests, fully extendable, as above but painted to requirement  
**Art. no. 1071-H**



**Art. no. 1064-H**

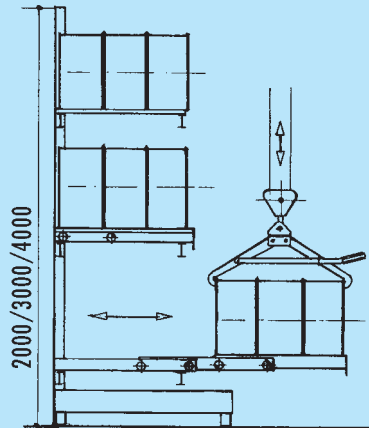

Barrel rests fully extendable



Barrel rests retracted - **Art. no. 1071-H**



Can holder, galvanised  
**Art. no. 1339**



Barrel rest, rolling, galvanised  
**Art. no. 1335**

**Barrel tool  
WERAX:**

for clean and simple emptying and filling of barrels with clamp lock for high and low-viscosity media.



Barrel rests fully extendable for re-equipping - **Art. no. 1071-H**

| Art. no.      | Type                                    |
|---------------|---|
| WERAX/VITON   | with Viton seal                         |
| WERAX/VITON/T | with Viton seal and dead-man's position |



Full pallet extension = 100%

**Pallet extension drawer = 100 % (see fig.)**  
**Max. load: 500 kg per extension**

**Extension drawer**

| Shelf depth | Width   | Useful depth | Useful width | Max. load |
|-------------|---------|--------------|--------------|-----------|
| 1300 mm     | 1340 mm | 1020 mm      | 1220 mm      | 500 kg    |

**Pallet extension drawers for light and heavy loads**

For re-fitting pallet shelves with one-sided 2/3 extension for up to 1000 kg maximum load and with full extension of 100% with a maximum load of 500 kg.

The pallet drawers are characterised by quick access and simple uncomplicated handling.

The pallet drawers are installed in the shelves taking exact account of the maximum loads. It must be ensured that the support beams of the pallet shelves are of sufficient size and strength. If necessary obtain a structural certificate.

The pallets can be placed in the store by crane or fork-lift in such a way as to save space (due to the extension drawer).

**Function and operation:**

If there is more than one drawer unit in the bays on one level, only one extension should be pulled out at any one time.

Each extension has an extension stop with lock to UVV-BGB 234.

Prices: on request according to quantity, dimensions and max. load

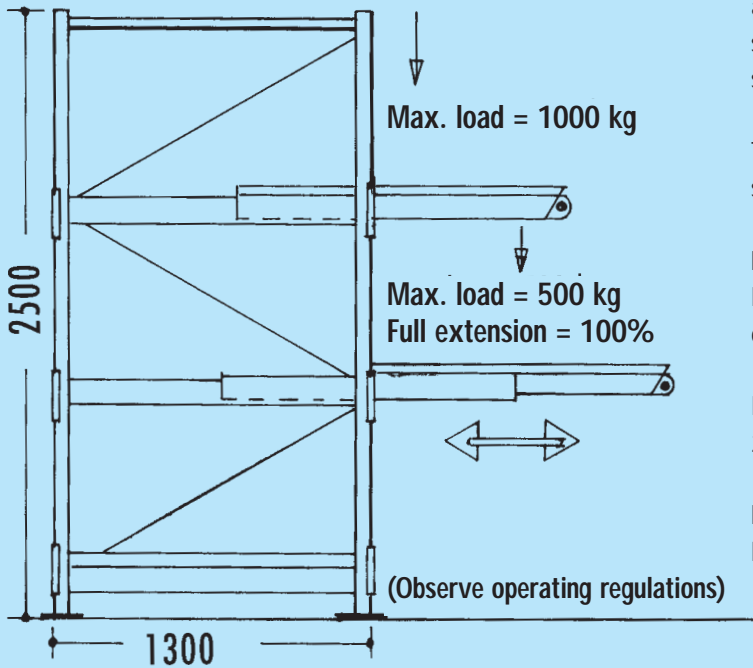

**- Special sizes on request -**



Heavy load 2/3 extension

**Pallet drawer with a 2/3 extension (see photo)**

**Max. load: 1000 kg per drawer**

**Drawer**

| Shelf depth | Shelf width | Useful depth | Useful width |
|-------------|-------------|--------------|--------------|
| 1300 mm     | 870 mm      | 1220 mm      | 820 mm       |
| 1300 mm     | 1340 mm     | 1220 mm      | 1220 mm      |
| 900 mm      | 1340 mm     | 820 mm       | 1220 mm      |

## Work and installation platforms - folding and rigid types



- Safety tested to BGV-BGR 500 and UVV of Liability Insurance Assoc.
- for use with fork-lift truck with fork pockets and locking bolt to prevent accidental slipping (see diagram).
- Technical description: standing surface as non-skid basin, designed for 2 persons.
- The folding structure is erected and dismantled in a few easy movements using a folding clamping and locking system for added safety.
- The folding rear wall is fitted with a safety grid
- Maximum load: 300 kg (2 persons)
- Surface: paint colour RAL 2000

### Construction of a work platform

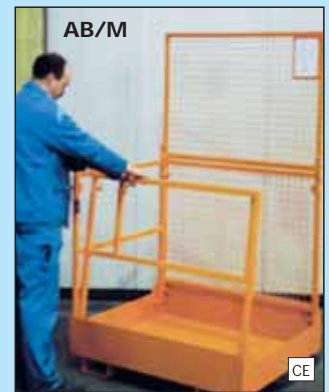

| Art. no.   | Description                          | Dimensions                         |
|------------|--------------------------------------|------------------------------------|
| AB/M       | Work platform, folding               | L x W x H<br>1000 x 1200 x 1890 mm |
| AB/M-ST    | Work platform, rigid                 | L x W x H<br>1000 x 1200 x 1890 mm |
| AB/M-ST-KR | Work platform, rigid Type: for crane | L x W x H<br>850 x 1200 x 2250 mm  |
| AB/M-ST-S  | Work platform, rigid Type: narrow    | L x W x H<br>1200 x 850 x 1890 mm  |



With wheel set  
 Wheel set: polyamide  
 2 x fixed wheels Ø 150 mm  
 2 x swivel wheels Ø 150 mm with brake

### Model: AB/M-ST-S

| Accessories | Description         | Dimensions  |
|-------------|---------------------|---|
| AB/M-W      | Tool shelf          |   |
| AB/M-R      | Wheel set polyamide | 2 fixed wheels Ø 150 mm<br>2 swivel wheels with brake |

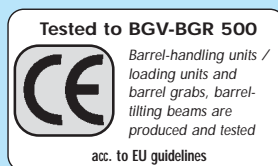

Standing base suitable as fork pockets

- A = 600 mm
- B = 200 mm
- C = 80 mm

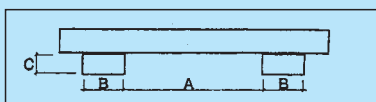

Crane-suspendable type  
 Model: AB/M-ST-KR

The ideal storage and transport system for cranes and fork-lifts



## Long-material cassettes

- Storage and transport of material in rod or bar format
- Max. load, 2000 kg each
- Stackable in 6 tiers
- Fitted with standard fork-lift pockets and crane lifting rings
- Perfect protection for long-format material during storage and handling
- Enclosed type ideal for storing shorter lengths

Welded steel-sheet construction with fork-lift pockets and rings for crane suspension. Colour: RAL 6011/RAL 5010. These cassettes are perfect for the safe transport of long material of steel, plastic etc.

| Long-mat. cassettes |        | Short       | Medium      | Long I      | Long II     | Very long   |
|---------------------|--------|-------------|-------------|-------------|-------------|-------------|
| Length approx.      | mm     | 1500        | 3500        | 4000        | 5000        | 6100        |
| Dim.: L app.        | mm     | 680         | 680         | 680         | 680         | 680         |
|                     | W app. | 490         | 490         | 490         | 490         | 490         |
| Full height         | mm     | 300         | 300         | 300         | 300         | 300         |
| Full width          | mm     | 500         | 500         | 500         | 500         | 500         |
| Fork-lift pockets   |        |             |             |             |             |             |
| Centre distance     | mm     | 740         | 740         | 740         | 740         | 740         |
| Fork-lift pockets   |        | 185 x 75    |             |             |             |             |
| Interior size       | mm     | 185 x 75    |             |             |             |             |
| Weight approx.      | kg     | 55          | 95          | 105         | 124         | 146         |
| <b>Art. no.</b>     |        | <b>1500</b> | <b>1501</b> | <b>1502</b> | <b>1503</b> | <b>1505</b> |



## Chassis

**Max. load 650/1400/2000 kg**

For efficient plant-internal transport.

Material: welded steel profiles. Colour: RAL 6011/RAL 5010  
2 swivelling and 2 fixed wheels with solid rubber tyres on steel rims. Max. loads = 650/1400 kg, with Vulkollan = 2000 k



| Chassis   |                 | short       | medium /long | very long   |
|---|-----------------|-------------|--------------|-------------|
| Sizes: length<br>width<br>height                    | mm              | 1280        | 1880         | 3000        |
|   | mm              | 650         | 650          | 650         |
|   | mm              | 500         | 500          | 500         |
| Max. load 650 kg<br>Wheel-Ø 200 mm<br>Solid rubber  | Weight          | 33 kg       | 49 kg        |             |
|   | <b>Art. no.</b> | <b>1600</b> | <b>1700</b>  |             |
| Max. load 1400 kg<br>Wheel-Ø 200 mm<br>Solid rubber | Weight          | 36 kg       | 52 kg        | 66 kg       |
|   | <b>Art. no.</b> | <b>1601</b> | <b>1701</b>  | <b>1801</b> |
| Max. load 2000 kg<br>Wheel-Ø 200 mm<br>Vulkollan    | Weight          | 58 kg       | 74 kg        | 88 kg       |
|   | <b>Art. no.</b> | <b>1602</b> | <b>1702</b>  | <b>1802</b> |



## Loading stand

For easy loading of cassettes  
Just place material on stand and lift the cassette under it.  
Paint colour: RAL 6011/RAL 5010  
H x W: 1100 x 540 mm  
Weight: 21 kg

**Art. no.**  
**1703 (pair)**



## Hook-in doors

Front closing for storing residual and cut material.  
When not in use, can be hooked to the lengthwise side.  
Paint colour: RAL 6011/RAL 5010  
Weight: 4,0 kg

**Art. no.**  
**1504 (pair)**

Compartment divider for crosswise division of cassette, push-in bolts: price on request!

For transporting and storing long-format material, basin shaped (also suitable for small-sized material). Stackable in 6 tiers, max. weight of contents 2000 kg.



## Storage and transport cassette

Stackable in several tiers with suspension rings and fork-lift pockets, additional interior lining with hook-in partition walls, suitable for small parts.



## Storage cassette, special type

Stackable, with fork-lift pockets and extendable closing plates at front.



## Storage cassette

with push-in dividers



## Storage cassette with chassis



## Heavy-duty chassis

Prices on request!



Art. no. KR-1



Art. no. KR-5

## Crane jibs

for positioning load from above or for installing and removing machine components. Crane jibs increase the range of the fork-lift truck.

Locking bolt prevents accidental slipping.

Welded steel construction to UVV.

Surface:

paint colour RAL 2000 or hot galvanised to DIN EN ISO 1461

Overall width:

520 mm

Overall height:

600 mm

Size of fork-lift pockets:

200 x 80 mm

Inner dimens. of fork-lift pockets:

190 x 70 mm

|                                      | Max. load     | Length         | Painted Art. no. | Galvanised Art. no. |
|--------------------------------------|---------------|----------------|------------------|---------------------|
| Rigid type                           | 2000 kg       | 2000 mm        | KR-1             | KR-2                |
| Rigid type, 6 length settings        | 650 – 3000 kg | 2000 – 3700 mm | KR-3             | KR-4                |
| 5 height settings, 6 length settings | 650 – 3000 kg | 2000 – 3700 mm | KR-5             | KR-6                |
| 5 height settings, 6 length settings | 800 – 5000 kg | 2000 – 3700 mm | KR-7             | KR-8                |

## The ideal versatile add-on for fork-lift trucks!



Crane jib 5 height settings, 6 length settings.

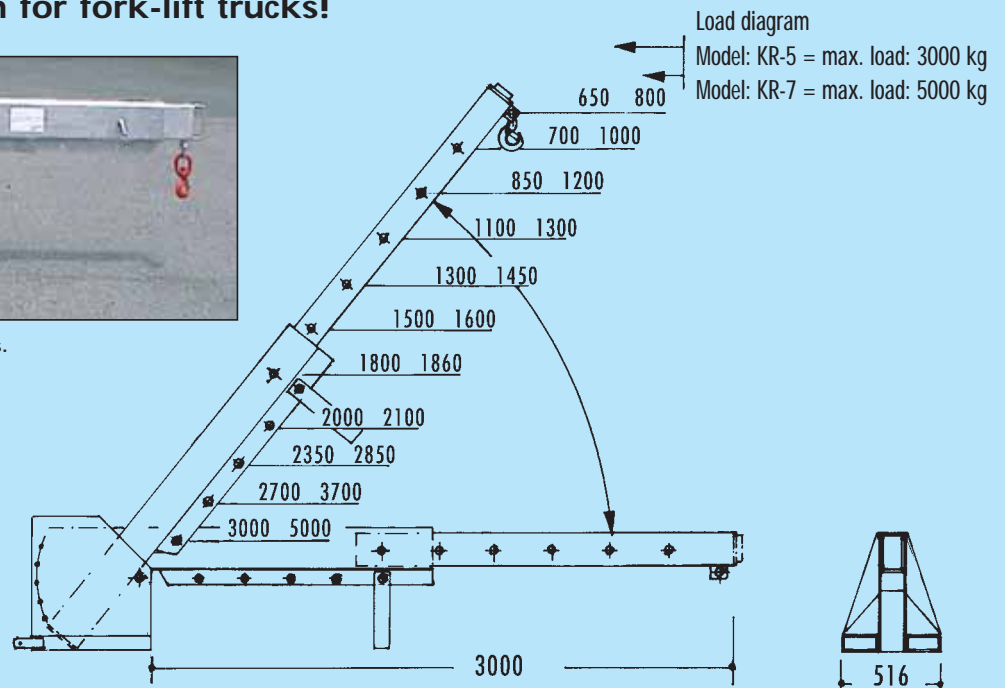



## Type KR-F/EH 100 H

- Fully hydraulic -

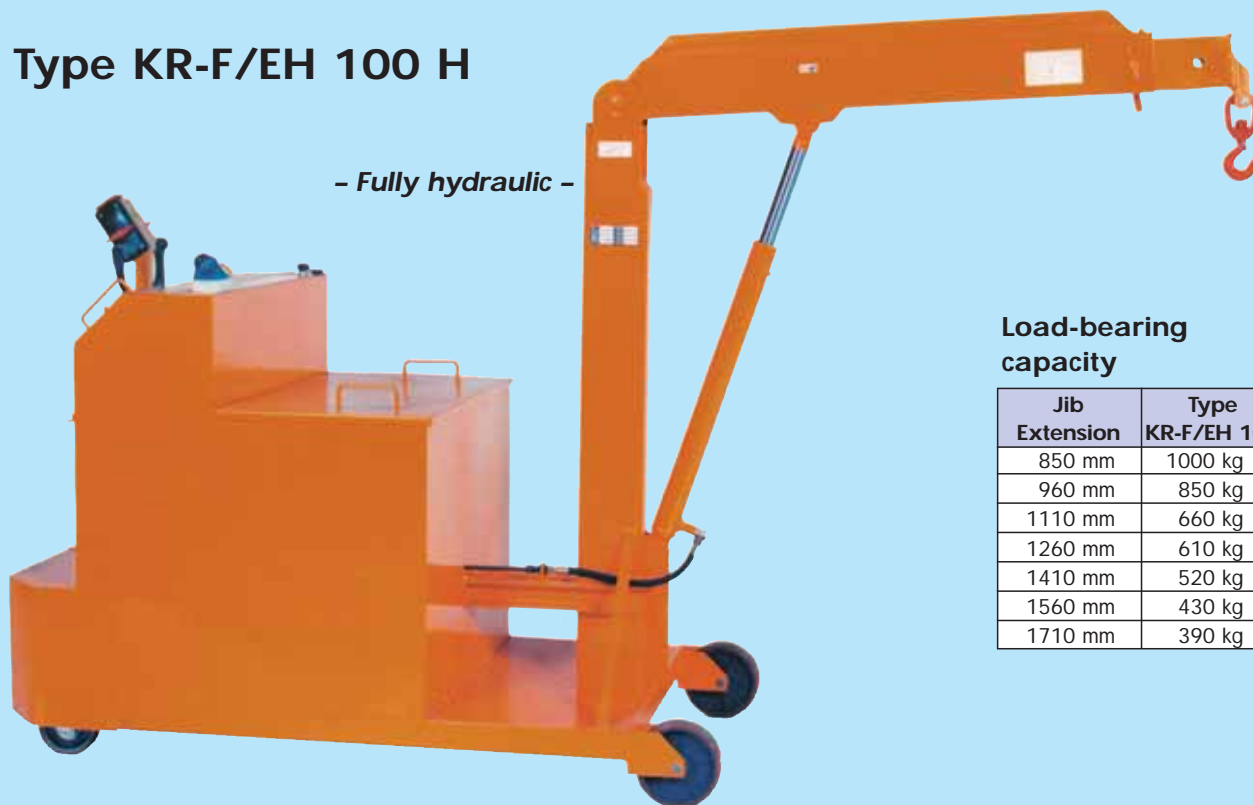

### Load-bearing capacity

| Jib Extension | Type KR-F/EH 100 |
|---------------|------------------|
| 850 mm        | 1000 kg          |
| 960 mm        | 850 kg           |
| 1110 mm       | 660 kg           |
| 1260 mm       | 610 kg           |
| 1410 mm       | 520 kg           |
| 1560 mm       | 430 kg           |
| 1710 mm       | 390 kg           |

### Workshop and assembly crane, bar-guided

#### Electric walking-pace drive system:

With planetary gears and electromagnetically released spring-force brake.

#### Guide bar:

With butterfly power switch and safety-impact switch, pneumatic spring.

#### Hydraulic system:

With permanently installed compact 24-V unit with start protector, hydraulic pump, adjustable pressure-control valve, oil tank and adjustable flow-control valve.

#### Electrical system:

Fully wired and installed with charging plug and key switch enclosed in a housing unit with cover for battery set and charging device. Design acc. to UVV with CE test in accordance with EU guidelines for machines 98/37/EG and BGV-BGR 500  
Paint colour: RAL 2000

### Workshop and assembly cranes, electrically

| Art. no.   | Description   |
|------------|---|
| KR-F/EH100 | Workshop and assembly crane, fully hydraulic powered with electrical walking-pace drive unit, ready for operation, complete with counterweight. Max. load: 390/1000 kg acc. to load diagram |

| Technical data              |                |
|-----------------------------|----------------|
| Dimensions L x W            | 1800 x 900 mm  |
| Stroke (hook height) of jib |                |
| retracted                   | 850 - 2450 mm  |
| extended                    | 2800 - 3200 mm |
| Column height               | 1750 mm        |
| Ballast counterweight       | 1150 kg        |
| Max. wheel load             | 1600 kg        |
| Drive wheel (Vulkollan)     | Ø 270 mm       |



#### Special type:

All models also available with extended trolley legs. (See fig. opposite)



- Subject to technical modification -

- manually manoeuvrable -



| Max. load KR-F 50 H |            |
|---------------------|------------|
| Projection in mm    | Load in kg |
| 860 mm              | 500 kg     |
| 1010 mm             | 435 kg     |
| 1160 mm             | 370 kg     |
| 1310 mm             | 330 kg     |
| 1460 mm             | 300 kg     |
| 1610 mm             | 275 kg     |
| 1760 mm             | 250 kg     |

**Model: KR-F 50 H**  
**Max. load: 500 kg**

Manufactured and tested acc. to EU guidelines with CE declaration, to UVV and BGV-BGR 500

Paint colour:  
 RAL 2000 yellow-orange  
 Special finish on request

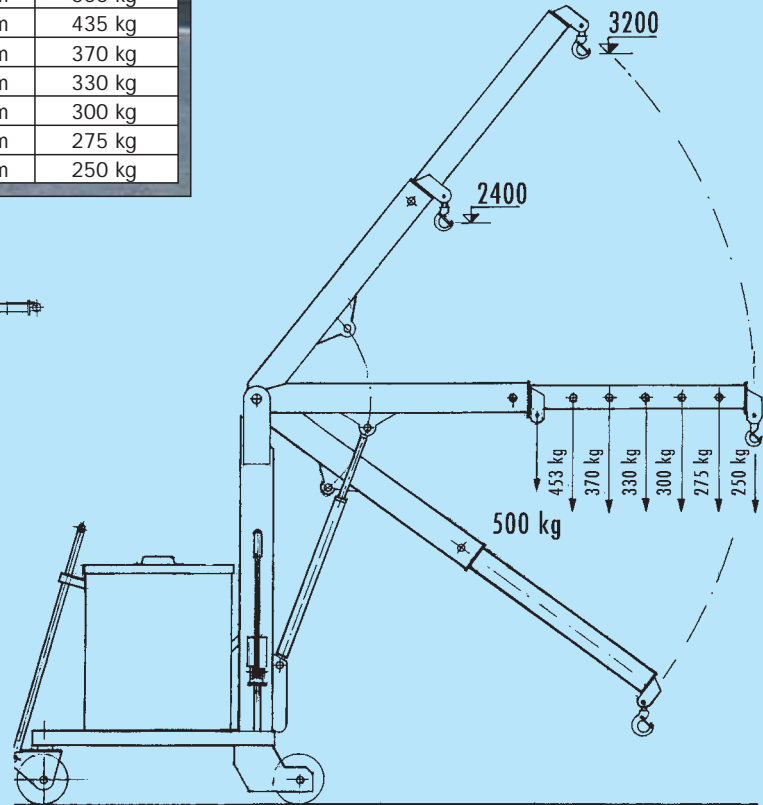
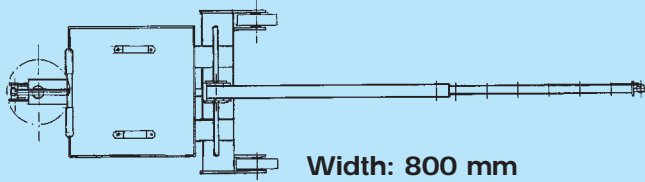

**The all-rounder for universal use in workshop**

- You can manoeuvre the load up to any machine, shelf, truck on cantilevered jib
- Suitable for confined spaces with guiding and drawing bar, manually manoeuvrable
- Manufactured of steel in compact design, with added ballast counterweight holder
- For filling with ballast acc. to table and load diagram

**Design features:**

- Telescoping jib with push-in bolts and spring-loaded pin (6 possible settings) with securing device, rotating load hook to DIN 15.401
- Lifting cylinder with hard-chrome plated piston rod
- Hydraulic pump with manual lever and precisely-adjustable venting valve

**Trolley:**

with integrated polyamide heavy-duty wheels 200 mm Ø.

**For heavy loads:**

now available with ratchet drive (Price on request!)

**Trolley lock:**

By raising guide bar and locking with spring bolt

**Workshop and assembly crane, manually manoeuvrable**

|   |         |
|---|---------|
| Column height   | 1750 mm |
| Wheelbase – length  | 1050 mm |
| Wheelbase – width   | 680 mm  |
| Trolley – length  | 1250 mm |
| Trolley – width   | 800 mm  |
| Highest hook position   |         |
| Crane jib, retracted  | 2400 mm |
| Crane jib, extended   | 3200 mm |
| Lowest hook position  |         |
| Crane jib, retracted  | 850 mm  |
| Crane jib, extended   | 280 mm  |
| Wheel-Ø   | 200 mm  |
| Ballast counterweight for 500 kg                              | 850 kg  |
| Weight without ballast approx.                                | 170 kg  |
| <b>Art. no.</b>   |         |
| <b>KR-F 50 H</b>  |         |
| Ballast counterweight 850 kg                                  |         |
| Heavy-duty Vulkollan wheels with manufacturer's ball bearings |         |

- Subject to technical modification -

- manually manoeuvrable -

**Model: KR-F 100 H**  
**Max. load: 1000 kg**

Manufactured and tested acc. to EU guidelines with CE declaration, to UVV and BGV-BGR 500

Paint colour:  
 RAL 2000 yellow-orange  
 Special finish on request

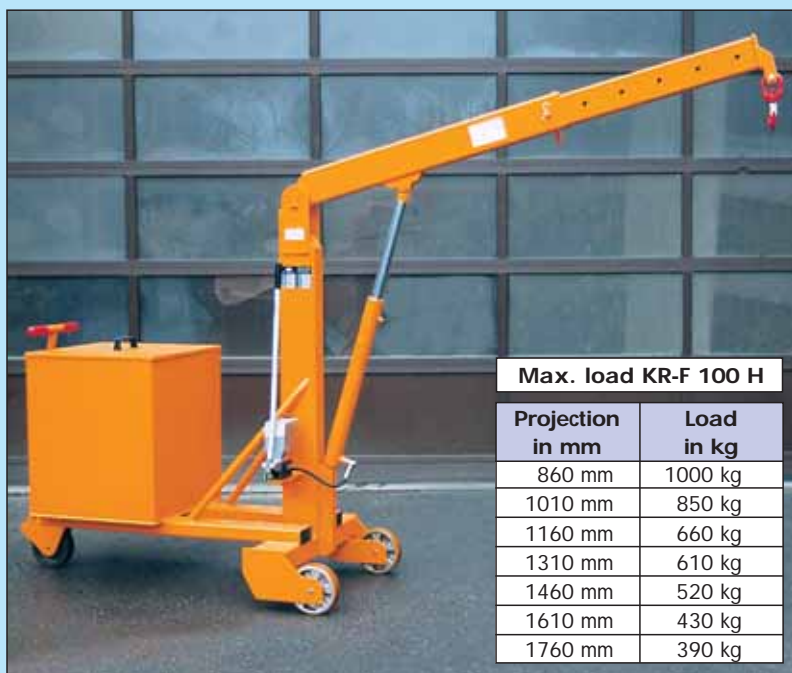

| Max. load KR-F 100 H |            |
|----------------------|------------|
| Projection in mm     | Load in kg |
| 860 mm               | 1000 kg    |
| 1010 mm              | 850 kg     |
| 1160 mm              | 660 kg     |
| 1310 mm              | 610 kg     |
| 1460 mm              | 520 kg     |
| 1610 mm              | 430 kg     |
| 1760 mm              | 390 kg     |

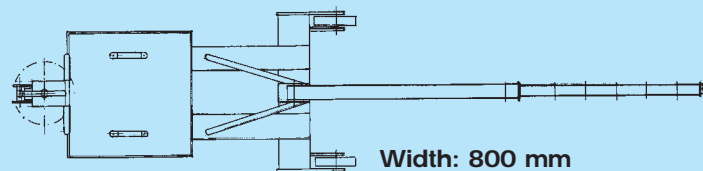

### The all-rounder for universal use in workshop

- You can manoeuvre the load up to any machine, shelf, truck on cantilevered jib
- Suitable for confined spaces with guiding and drawing bar, manually manoeuvrable
- Manufactured of steel in compact design, with added ballast counterweight holder
- For filling with ballast acc. to table and load diagram

### Design features:

- Telescoping jib with push-in bolts and spring loaded pin (6 possible settings) with securing device, rotating load hook to DIN 15.401
- Lifting cylinder with hard-chrome plated piston rod
- Hydraulic pump with manual lever and precisely adjustable venting valve

### Trolley:

with integrated polyamide heavy-duty wheels 200 mm Ø.

### For heavy loads:

now available with ratchet drive (Price on request!)

### Trolley lock:

By raising guide bar and locking with spring bolt

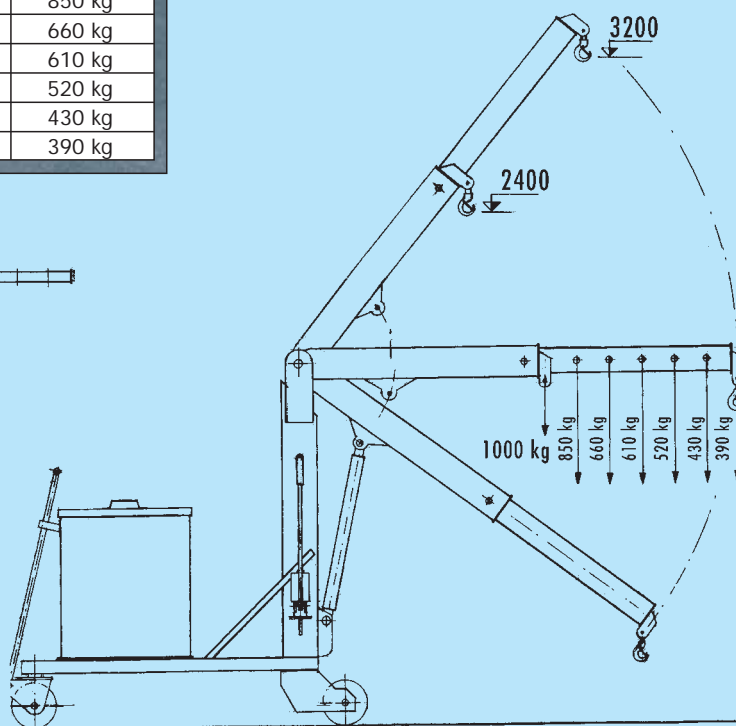

### Workshop and assembly crane, manually manoeuvrable

|   |         |
|---|---------|
| Column height   | 1750 mm |
| Wheelbase - length  | 1450 mm |
| Wheelbase - width   | 680 mm  |
| Trolley - length  | 1650 mm |
| Trolley - width   | 800 mm  |
| Highest hook position   |         |
| Crane jib, retracted  | 2400 mm |
| Crane jib, extended   | 3200 mm |
| Lowest hook position  |         |
| Crane jib, retracted  | 850 mm  |
| Crane jib, extended   | 280 mm  |
| Wheel-Ø   | 200 mm  |
| Ballast counterweight for 1000 kg                             | 1150 kg |
| Weight without ballast approx.                                | 210 kg  |
| <b>Art. no.</b>   |         |
| <b>KR-F 100 H</b>   |         |
| Ballast counterweight 1150 kg                                 |         |
| Heavy-duty Vulkollan wheels with manufacturer's ball bearings |         |

- Subject to technical modification -

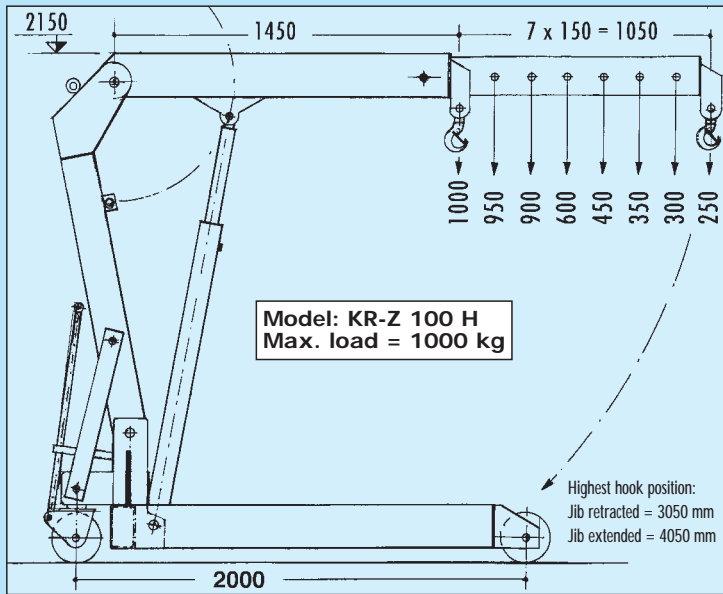

## Industrial crane KR-Z 100 H

|  |         |
|--|---------|
| Column height  | 2150 mm |
| Wheel base – length  | 2000 mm |
| Wheel base – width   |         |
| Parallel   | 1100 mm |
| Diverging  | 1500 mm |
| Highest hook position  |         |
| Jib retracted  | 3050 mm |
| Jib extended   | 4050 mm |
| Lowest hook position   |         |
| Crane jib retracted  | 750 mm  |
| Crane jib extended   | 280 mm  |
| Overall height in folded pos.  | 600 mm  |
| Wheel-Ø  | 200 mm  |
| Weight approx.   | 230 kg  |
| <b>Art. no.</b>  |         |
| <b>KR-Z 100 H/G</b> , diverging type                                       |         |
| <b>KR-Z 100 H/P</b> , parallel type  |         |
| Extra price: Heavy-duty Vulkollan wheels with manufacturer's ball bearings |         |

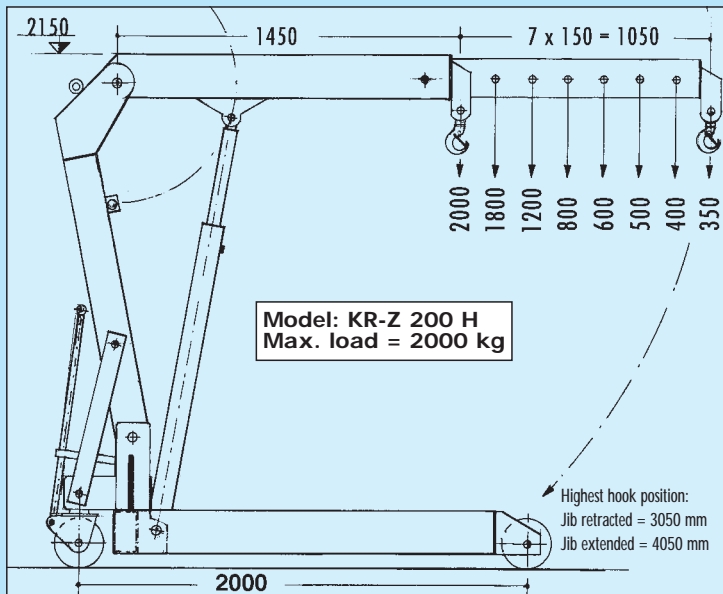

## Industrial crane KR-Z 200 H

|  |         |
|--|---------|
| Column height  | 2150 mm |
| Wheel base – length  | 2000 mm |
| Wheel base – width   |         |
| Parallel   | 1100 mm |
| Diverging  | 1500 mm |
| Highest hook position  |         |
| Jib retracted  | 3050 mm |
| Jib extended   | 4050 mm |
| Lowest hook position   |         |
| Crane jib retracted  | 750 mm  |
| Crane jib extended   | 280 mm  |
| Overall height in folded pos.  | 600 mm  |
| Wheel-Ø  | 200 mm  |
| Weight approx.   | 330 kg  |
| <b>Art. no.</b>  |         |
| <b>KR-Z 200 H/G</b> , diverging type                                       |         |
| <b>KR-Z 200 H/P</b> , parallel type  |         |
| Extra price: Heavy-duty Vulkollan wheels with manufacturer's ball bearings |         |

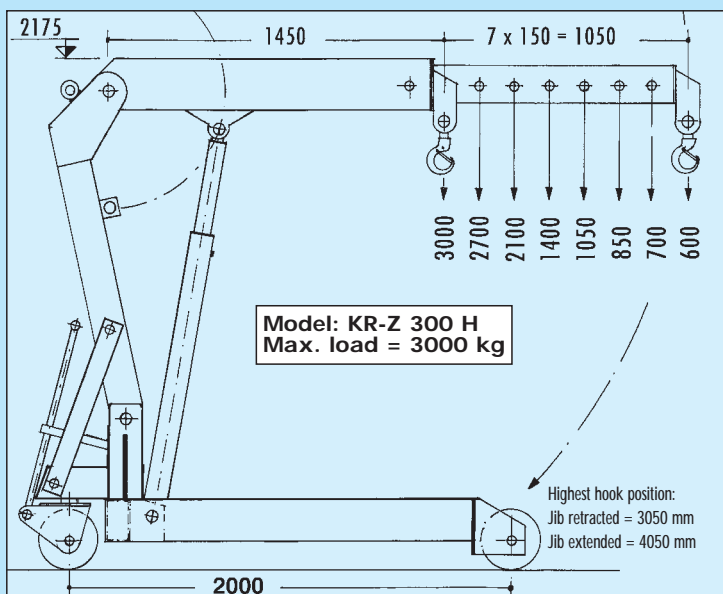

## Industrial crane KR-Z 300 H

|  |         |
|--|---------|
| Column height  | 2175 mm |
| Wheel base – length  | 2000 mm |
| Wheel base – width   |         |
| Parallel   | 1300 mm |
| Diverging  | 1500 mm |
| Highest hook position  |         |
| Jib retracted  | 3050 mm |
| Jib extended   | 4050 mm |
| Lowest hook position   |         |
| Crane jib retracted  | 750 mm  |
| Crane jib extended   | 280 mm  |
| Overall height in folded pos.  | 600 mm  |
| Wheel-Ø  | 250 mm  |
| Weight approx.   | 460 kg  |
| <b>Art. no.</b>  |         |
| <b>KR-Z 300 H/G</b> , diverging type                                       |         |
| <b>KR-Z 300 H/P</b> , parallel type  |         |
| Extra price: Heavy-duty Vulkollan wheels with manufacturer's ball bearings |         |

– Subject to technical modification –

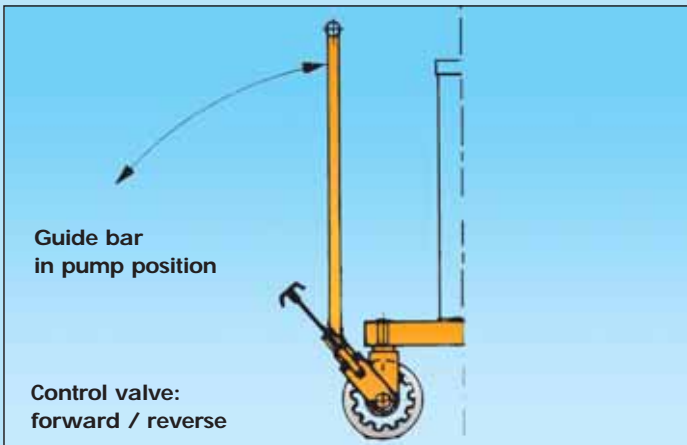

Guide bar with ratchet drive for heavy loads (for cranes of all sizes)

**Load diagram**

| Projection in mm | Max load in kg |            |            |
|------------------|----------------|------------|------------|
|                  | KR-Z 100 H     | KR-Z 200 H | KR-Z 300 H |
| 1450 mm          | 1000           | 2000       | 3000       |
| 1610 mm          | 950            | 1800       | 2700       |
| 1760 mm          | 900            | 1200       | 2100       |
| 1910 mm          | 600            | 800        | 1400       |
| 2060 mm          | 450            | 600        | 1050       |
| 2210 mm          | 350            | 500        | 850        |
| 2360 mm          | 300            | 400        | 700        |
| 2510 mm          | 250            | 350        | 600        |

**The multi-purpose industrial crane**  
**Max. load: 1000 kg, 2000 kg, 3000 kg**

for universal use in the factory, workshop or construction site. Manoeuvrable by hand, collapsible and fitted with hydraulic power unit for lifting.

**Design features:** rugged, torsion-free, steel construction of welded hollow profiles. Telescopic jib with 7 different settings and securing device. Rotating load hook to DIN 15401.



Can be assembled and dismantled in a few easy movements by means of socket pins

**Chassis:** with drawing and steering bar (forced steering rotatable on the spot) fitted with polyamide wheels of 200 - 250 mm Ø depending on max. load

**Chassis-securing system:** by raising the steering bar and locking it with spring bolt. Lifting cylinder suspended in pendulum position with hard chrome plated piston rod. Single-action hydraulic pump with finely adjustable venting valve. Maintenance-free.

Secured against overloading.

When erecting, proceed in the following order:

- 1) Move column and jib into upright position.
- 2) Connect column with diagonal ties and secure with socket pin.
- 3) Set up the hydraulic cylinder, connect it with the jib and secure it with socket pin.

The crane can be dismantled in a few minutes by releasing the socket pins and proceeding in the opposite order. It can be folded down for easy transport or storage. The crane is delivered complete with oil charge in the folded state either by rail or road transport.

Finish: RAL 2000 – yellow-orange

**Chassis**

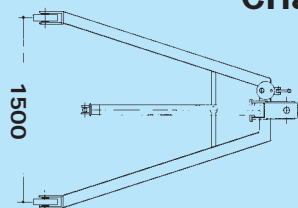

Type: diverging

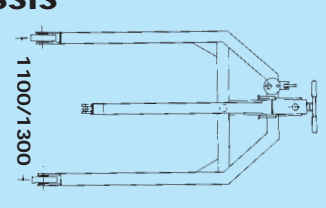

Type: parallel

– Subject to technical modification –



**MEILLER GmbH & Co. KG**  
**Lifting, Storage and Environment Technology**

**Auf der Lake I · D-57392 Schmallenberg**  
**Postfach 1320 · D-57378 Schmallenberg**

**Telephone +49 (0) 29 72 / 97 42-0**  
**Telefax +49 (0) 29 72 / 97 42-20**

**[www.meiller-umwelttechnik.de](http://www.meiller-umwelttechnik.de)**  
**[info@meiller-umwelttechnik.de](mailto:info@meiller-umwelttechnik.de)**



